



LABORATORY TECHNOLOGY®
Buddleberg



MIXING TECHNOLOGY



- 
- ✓ More than 137 years of experience in laboratory supply
 - ✓ Wide choice of model variants
 - ✓ Special versions tailored to your wishes
 - ✓ Explosion protection

Customised products

We are able to go beyond the catalogue range. We offer individual consultations in which we take your specific requirements into account and develop customised products. This gives you the best possible solution for your needs.

ATEX Certification

The compressed air stirrers from Buddeberg GmbH are explosion-protected according to the current ATEX regulation 2014/34/EU and are assigned to equipment group II, zone 1 and 2 for gas atmosphere G and/or can be offered for dust atmosphere D too. Compressed air stirrers of equipment group II include the explosion subgroups IIA, IIB and IIC, and can thus be used for mixing work in these areas.

Contact person

We attach great importance to offering our customers a personalised and individual service. For this reason, at Buddeberg you have a personal contact person at your side, who will be happy to help you with any questions or concerns you may have.



Marcel Schreiber
+49 621 87690-52
schreiber@buddeberg.de



Sabine Hohmann
+49 621 87690-40
hohmann@buddeberg.de



Marcel Bahrdt
+49 621 87690-24
bahrdt@buddeberg.de

MIXING TECHNOLOGY

Since 1887 we have been specialised as distributors and producers of laboratory equipment. Buddeberg mixing technology production range provides explosion-protected compressed air laboratory stirrers and industrial stirrers, pharma and food grade stirrers as well as magnetic stirrer couplings for a variety of applications and industries.

Our proven and well thought-out range is continuously being developed and optimised in order to be able to offer you tailor-made solutions for every challenge in the field of mixing technology. A wide selection of different model variants offers the right agitator for every conceivable stirring task in a broad viscosity range. For stirring tasks outside the standard range, we offer customised products in any design.

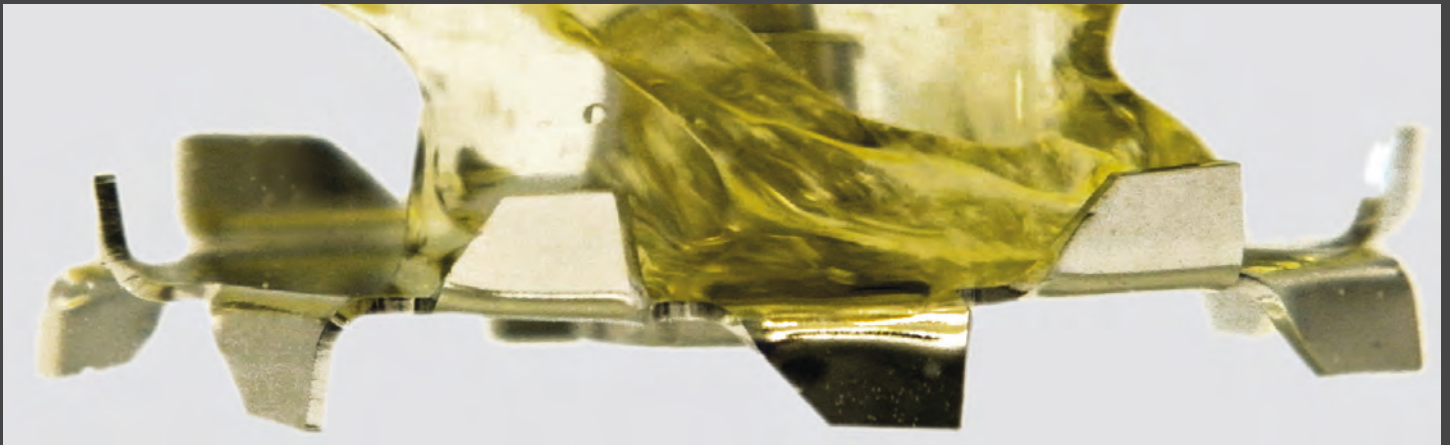
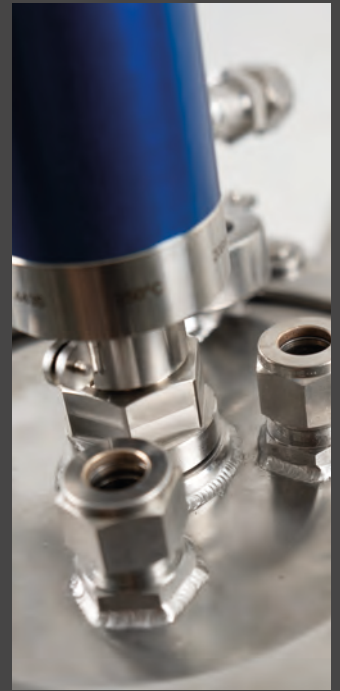

10-19

Compressed air
Laboratory stirrers

MODEL SERIES



20-24

Compressed air
Laboratory stirrers

STIRRING ROTORS

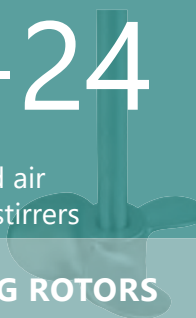

25-29

Compressed air
Laboratory stirrers

ACCESSORIES

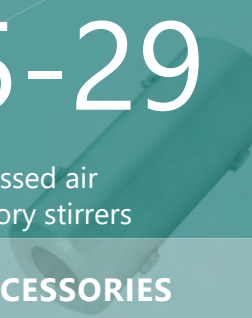

30-34

Pharma/Food
grade stirrers

MODEL SERIES



35

Pharma/Food
grade stirrers

STIRRING ROTORS



36-37

Pharma/Food
grade stirrers

ACCESSORIES



38-48

Compressed air
Industrial stirrers

MODEL SERIES



49-51

Compressed air
Industrial stirrers

STIRRING ROTORS



52-55

Compressed air
Industrial stirrers

ACCESSORIES



56-60

Compressed air
Container stirrers

MODEL SERIES

61

Compressed air
Container stirrers

STIRRING ROTORS

62-67

Magnetic stirrer couplings

MODEL SERIES

68-71

Magnetic stirrer couplings

STIRRING ROTORS

72-73

Magnetic stirrer couplings

ACCESSORIES

74

Magnetic stirrer drives

MODEL SERIES

Basic tasks of MIXING



Homogenising

One of the most common and widely used stirring tasks is homogenisation. The aim here is to reduce concentration and temperature differences resulting from product additions, mass transfer, chemical reactions or heat transfer, for example.

The most important factor for the stirring process is the viscosity, which determines the type of stirring tool, the tank geometry and the mixing time.

Suitable stirring rotors

Low to medium viscosity

BuddeMix, propeller stirring rotor, diagonal blade stirring rotor

Medium to high viscosity

BuddeMix, anchor stirring rotor



Suspending

Stirring solids into a liquid phase is known as suspending. The aim is usually to dissolve a solid component as quickly as possible or to distribute it evenly in the liquid phase and prevent sedimentation. In this stirring process, the solid is usually dosed onto the surface of the liquid and incorporated into the liquid phase using a suitable stirrer. Depending on its density, the solid can be lighter or heavier than the liquid.

When selecting the appropriate stirring tool, the shear sensitivity of the solid may also need to be taken into account. In some cases, it may be necessary to use a particularly low-shear stirring tool, such as the BuddeMix.

Suitable stirring rotors

Propeller stirring rotor, diagonal blade stirring rotor, BuddeMix



Dispersing

Dispersing is the mixing of two substances that are insoluble in each other or barely soluble in each other, for example to intensify the exchange of substances.

Dispersions (heterogeneous mixtures of substances) are unstable and segregate when there is no or little energy input. In the chemical industry, liquid-liquid dispersions are often produced for specific temporary reactions. Long-term stable dispersions are often produced in the pharmaceutical, cosmetics and food industries.

Dispersions that remain stable over a long period of time without the addition of energy are referred to as emulsions. Emulsifiers are often added to stabilise the dispersion.

Suitable stirring rotors

Dissolver stirring rotor



Gassing

The aim of gassing a liquid is to increase the phase interface between the liquid and the gas, for example to accelerate chemical reactions. The stirring tool must break up the gas flow, which is introduced into the liquid via a rising pipe, for example, into tiny bubbles and distribute them evenly in the liquid phase. This achieves the highest possible mass transfer between the dispersed gas and the liquid.

Gassing is used for chemical syntheses such as hydrogenation or oxidation, as well as for fermentation.

Suitable stirring rotors

Gas injection stirrer



Heat exchange

Many stirring processes require efficient heat transfer, which the agitator must fulfil in conjunction with the tank geometry and the temperature-transferring elements. A uniform flow covering the entire volume is essential, especially for viscous liquids.

Suitable stirring rotors

Low to medium viscosity

BuddeMix, propeller stirring rotor, diagonal blade stirring rotor

Medium to high viscosity

BuddeMix, anchor stirring rotor



The compressed air stirrers from Buddeberg GmbH are explosion-protected according to the current ATEX regulation 2014/34/EU and are assigned to equipment group II, zone 1 and 2 for gas atmosphere G and/or can be offered for dust atmosphere D too.

Compressed air stirrers of equipment group II include the explosion subgroups IIA, IIB and IIC, and can thus be used for mixing work in these areas.

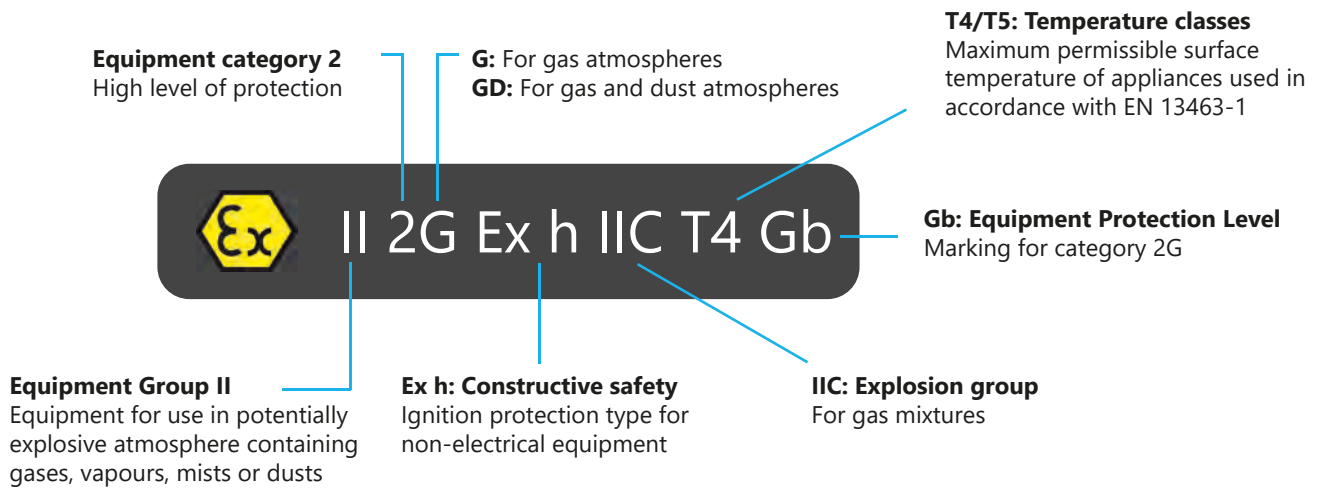

Marking	Description	Definition
II	Equipment Group II	Equipment for use in potentially explosive atmosphere containing gases, vapours, mists or dusts
2	Equipment category 2	High level of protection
G	For gas atmospheres	A place in which an explosive atmosphere in the form of a cloud of combustible dust in air is likely to occur in normal operation occasionally
GD	For gas and dust atmospheres	A place in which an explosive atmosphere in the form of a cloud of combustible dust in air is likely to occur in normal operation occasionally
Ex h	Constructive safety	Ignition protection type for non-electrical equipment
IIC	Explosion group for gas mixtures	Classification of ignitability of mixtures ranking from A (low) to C (high)
T4/T5	Temperature classes	Maximum permissible surface temperature of appliances used in accordance with EN 13463-1 T4: Max. 135°C, T5: Max. 100°C
Gb	Equipment Protection Level (EPL)	Marking for category 2G



How to select the correct

STIRRING ROTOR SIZE

Container diameter

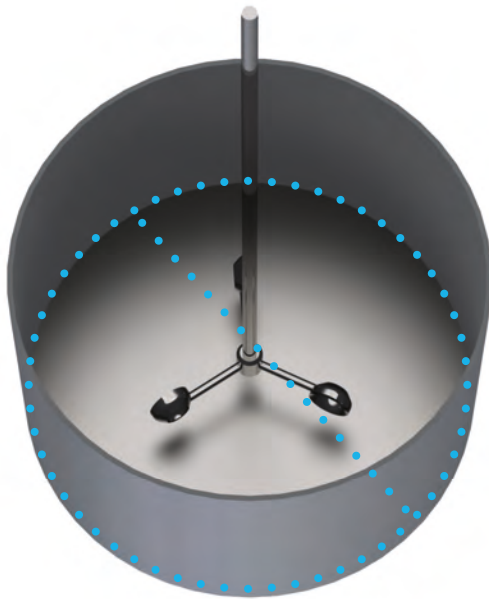

Stirring rotor size



BuddeMix

Correct stirring rotor size = Inside diameter of container x **min. 0.3 to max. 0.75**



Propeller stirrer

Correct stirring rotor size = Inside diameter of container x **min. 0.1 to max. 0.5**



Diagonal blade stirrer

Correct stirring rotor size = Inside diameter of container x **min. 0.25 to max. 0.5**



Anchor stirrer

Correct stirring rotor size = Inside diameter of container x **min. 0.9 to max. 0.98**



Dissolver stirrer

Correct stirring rotor size = Inside diameter of container x **min. 0.2 to max. 0.5**



Example BuddeMix

Inside diameter of container: 30 cm

$$30 \times 0.3 = 9$$

$$30 \times 0.75 = 22,5$$

The **stirrer diameter** may therefore be a minimum of 9 cm and a maximum of 22.5 cm

VISCOSITY AND FLOW CHARACTERISTIC

One of the most important parameters for the mixing technology

This applies to both the selection of a suitable stirring rotor and required performance of the stirrer drive. Viscosity describes the thickness or fluidity of liquids and/or fluids. In viscous liquids particles are bound together more strongly and thus less movable which is referred to as internal friction.

Dynamic viscosity is measured in pascal seconds (Pa·s) or millipascal seconds (mPa·s) (obsolete expression poise 'P' or centipoise 'cP').

Kinematic viscosity is expressed in m²/s. It describes the inner friction of a liquid and is calculated by dividing the dynamic viscosity by the density of a liquid.

Dynamic viscosity of common substances in comparison at 20°C and normal pressure:

Millipascal second mPa·s (centipoise cP)	Example
0.3	Acetone
1	Water
2	Milk
80	Olive oil
200	Maple syrup
3.000	Honey
5.000 - 10.000	Molasses
50.000 - 70.000	Ketchup
150.000 - 250.000	Tomato puree

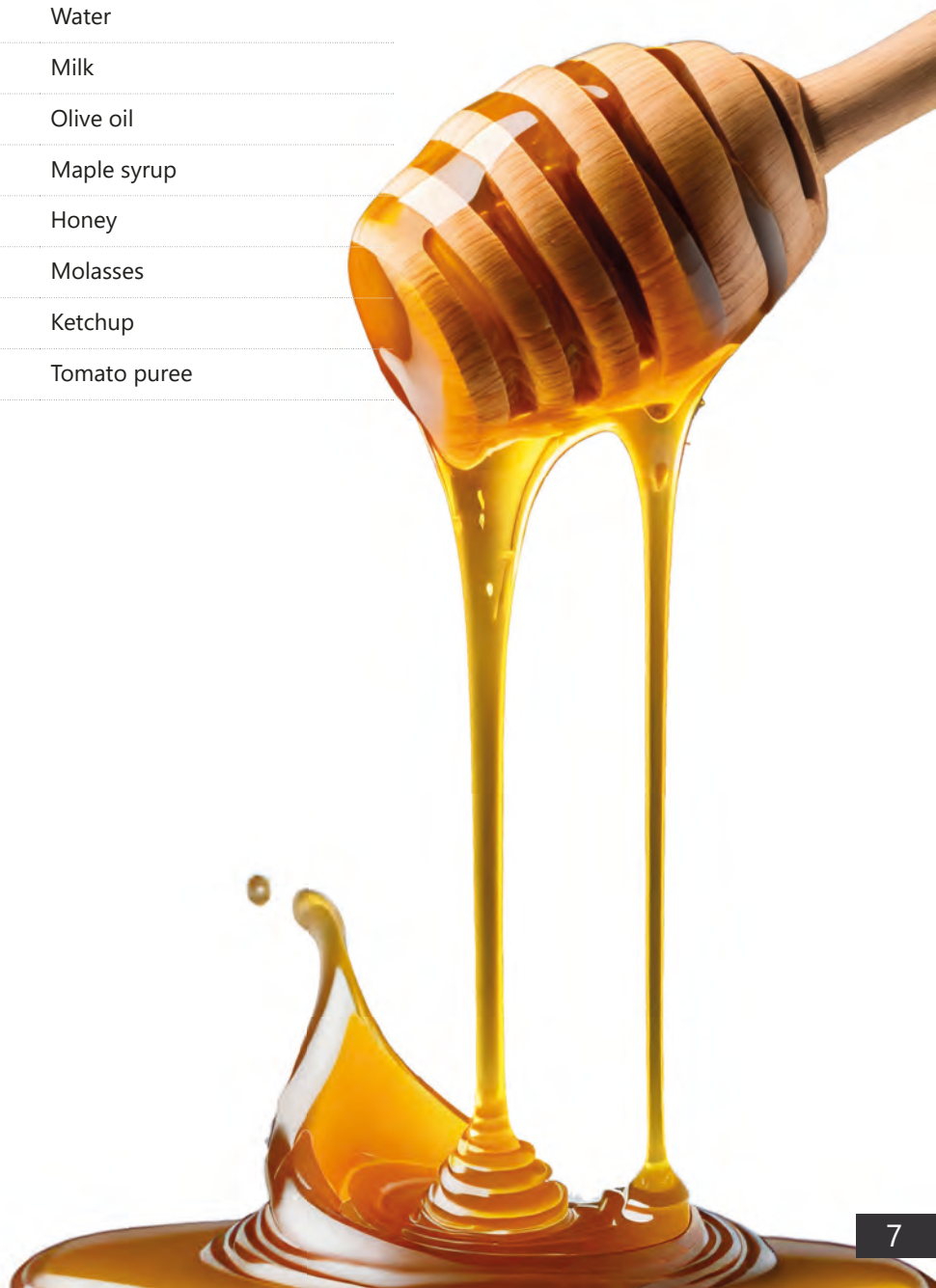

MATERIALS

Stainless steel 1.4301

X5CrNi18-10, AISI 304

Austenite, acid-resistant 18/10 Cr-Ni-steel

Resistance

Water, vapour, humidity, salt, acids in food and weak organic or inorganic acids.

Applications

Food industry, mechanical engineering, beverage production, pharmaceutical and cosmetics industry, chemical apparatus engineering.

Stainless steel 1.4435

X2CrNiMo18-14-3, AISI 316L

Austenite, acid-resistant Cr-Ni-Mo-steel

Resistance

Better corrosion resistance compared to Cr-Ni steel, resistant to organic or inorganic acids, media containing halogen, good resistance to intercrystalline corrosion. Improved pitting corrosion compared to 1.4404 due to the higher content of molybdenum. High temperature resistance up to 450°C.

Applications

Food industry, chemical industry, mechanical engineering, beverage production, pharmaceutical and cosmetics industry.

Hastelloy® B3, 2.4600

NiMo29Cr, Alloy B3

Nickel-molybdenum alloy

Resistance

Excellent corrosion resistance to reducing media as e.g. hydrochloric acid in its complete range of concentrations and temperatures, acetic acid, hydrogen chloride, sulphuric acid, phosphoric acid.

Applications

Chemical industry, phenol production.

Stainless steel 1.4404

X2CrNiMo17-12-2, AISI 316L

Austenite, acid-resistant Cr-Ni-Mo-steel

Resistance

Better corrosion resistance compared to Cr-Ni steel, resistant to organic or inorganic acids, media containing halogen, good resistance to intercrystalline corrosion. High temperature resistance up to 450°C.

Applications

Food industry, chemical industry, mechanical engineering, beverage production, pharmaceutical and cosmetics industry.

Stainless steel 1.4980

X6NiCrTiMoVB25-15-2, Alloy 286, AISI 660

High temperature resistant, austenite superalloy

Resistance

High corrosion resistance to organic or inorganic acids. Excellent thermal stability and corrosion properties at temperatures up to 800°C.

Applications

High pressure engineering, chemical industry, thermal process engineering. Excellent properties for applications under high pressure and temperature, e.g. with high pressure reactors.

Hastelloy® C22, 2.4602

NiCr21Mo14W, Alloy C22

Nickel-chrome-molybdenum-tungsten alloy

Resistance

High corrosion resistance to pitting, crevice and stress at high temperatures under oxidising and reducing conditions. Resistant to, for example sulphuric acid, acid mixtures from sulphuric acid, phosphoric acid, nitric acid, chlorine gas and oxidising acids with chloride ions.

Applications

Chemical industry, flue gas desulphurisation, cellulose and paper industry.

Kalrez® , FFKM (FFPM)

Group of fluoro- and perfluoro-elastomeres
FDA conform (compound 6221, 6230 only)

Resistance

Depending on the compound superior chemical resistance to acids, alkalis, amines, vapour, ethylene oxide as well as many other aggressive chemicals.

Temperature resistance -20°C to +275°C, at a brief time +325°C.

Applications

Sealing technology and especially high vacuum applications.

Viton® , FKM (FPM)

Fluor rubber, group of fluoroelastomeres
FDA conform

Resistance

Good chemical resistance to propane, butane and natural gas, fuels, mineral oils and greases, silicone oils and greases, and aromatic hydrocarbons. Temperature resistance -20°C to +250°C, at a brief time +300°C.

Applications

Sealing technology and especially high vacuum applications.

PTFE, Polytetrafluorethylen

Highly resistant plastic
FDA conform

Resistance

Superior chemical resistance because of its inertness. Extremely resistant to all bases, alcohols, ketones, benzines. The thermal capacity ranges from -260°C up to +250°C, at a brief time +300°C (e.g. no embrittlement of boiling helium at +269°C).

Applications

Chemical industry, apparatus construction, medical technology.



Compressed air

LABORATORY STIRRERS



The PLR series offers optimal stirrers for a variety of mixing tasks in the laboratory, pilot plants and in production under explosion-protected conditions. A broad selection of different model variants covers the requirements for all mixing tasks in a wide range of viscosities.

Our pneumatic lab mixers are suitable for stirring volumes from 0.5 to 60 liters. Depending on the model, PLR stirrers are fitted with exhaust air ducting for operation e.g. in clean rooms and/or isolators, or tachometer.

We offer special designs tailored to your wishes, e.g. special flange or TriClamp connections. Our choice of specialised stirring rotor shafts and accessories together with our compressed air laboratory stirrers offers the optimal solution for your stirring process.

All our stirrers are certified to ATEX regulation II 2G Ex h IIC T5 or T4 Gb.

Area of application: Paints and coatings industry, chemical industry, pharmaceutical industry, cosmetics industry, food industry.

Standard design

Used compressed air can escape freely via exhaust air holes on the housing.

No additional connections for an exhaust air duct are required.

T design

The T models are equipped with an analogue speed display and simplify reproducible stirring processes with the same speed.

GA design

GA models feature a separate outlet connection for ducting the exhaust air which leads to improved performance at low speed and results in reduced noise levels. Discharging the exhaust air also enables the use in clean rooms.

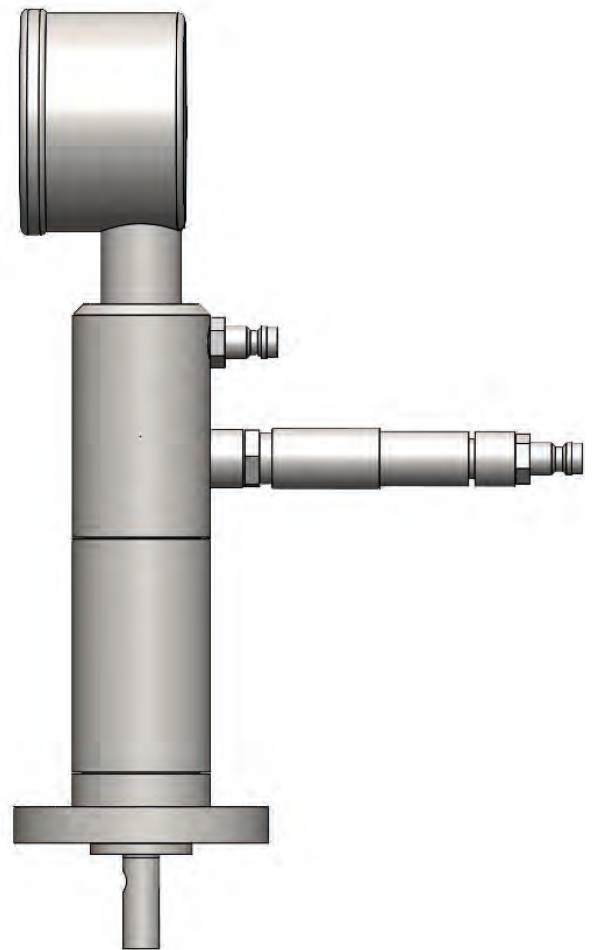

Volume



Volume up to 60 litres

Custom made



We offer custom designs, tailored individually to your requirements

ATEX certification



Our laboratory stirrers are explosion-protected according to the current ATEX regulation



Compressed air laboratory stirrers PLR 10 model series

General specifications

- All-stainless steel housing
- Operating pressure 3-6 bar
- Air consumption 260 L/min. at 6 bar
- Clockwise rotation
- ATEX certification

Basic models include

- Continuously adjustable speed control valve
- Support arm Ø 14 mm
- Plug-in connector for DN 5

Required accessories connection coupling type VK 10 not included.

Speed range

High to very high

Types of mixing

- Homogenising
- Gas injection
- Dispersing



Type	PLR 10	PLR 10 T	PLR 10 GA
Power output	200 Watt	200 Watt	200 Watt
Volume	3 L	3 L	5 L
Viscosity	1000 mPas	1000 mPas	1000 mPas
Torque	0.3 Nm	0.3 Nm	0.3 Nm
No-load speed	15000 rpm	15000 rpm	15000 rpm
Minimum operation speed	1000 rpm	1000 rpm	1000 rpm
ATEX	Ex II 2G Ex h IIC T4 Gb	Ex II 2G Ex h IIC T4 Gb	Ex II 2G Ex h IIC T4 Gb
Code-No.	40 26446 00247 3	40 26446 00248 0	40 26446 00480 4

Viscosity data to be considered as guidelines. All technical data pertaining to 6 bar.

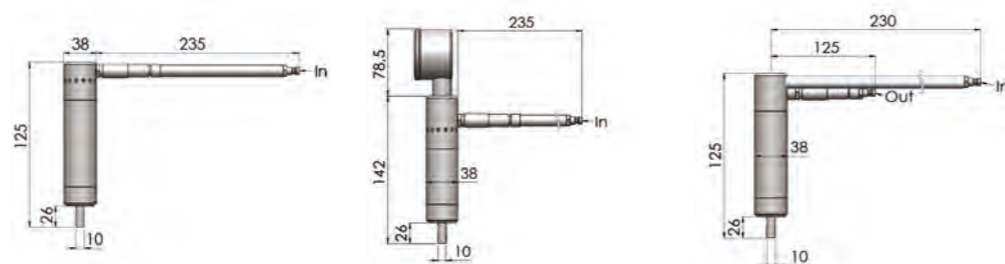

All dimensions in mm.

Standard design

Used compressed air can escape freely via exhaust air holes on the housing. No additional connections for an exhaust air duct are required.

T design

The T models are equipped with an analogue speed display and simplify reproducible stirring processes with the same speed.



Type	PLR 10 T GA	PMR 10 GA	PMR 10T GA
Power output	200 Watt	200 Watt	200 Watt
Volume	5 L	5 L	5 L
Viscosity	1000 mPas	1000 mPas	1000 mPas
Torque	0.3 Nm	0.3 Nm	0.3 Nm
No-load speed	15000 rpm	15000 rpm	15000 rpm
Minimum operation speed	1000 rpm	1000 rpm	1000 rpm
ATEX	Ex II 2G Ex h IIC T4 Gb	Ex II 2G Ex h IIC T4 Gb	Ex II 2G Ex h IIC T4 Gb
Code-No.	40 26446 00485 9	40 26446 00610 5	40 26446 00772 0

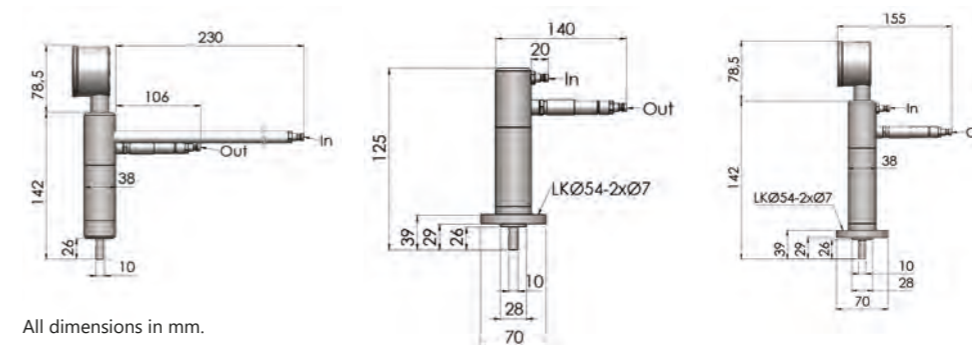

All dimensions in mm.

GA design

GA models feature a separate outlet connection for ducting the exhaust air which leads to improved performance at low speed and results in reduced noise levels. Discharging the exhaust air also enables the use in clean rooms.

Compressed air laboratory stirrers PLR 11 model series

General specifications

- All-stainless steel housing
- Operating pressure 3-6 bar
- Air consumption 260 L/min. at 6 bar
- Clockwise rotation
- ATEX certification

Basic models include

- Continuously adjustable speed control valve
- Support arm Ø 14 mm
- Plug-in connector for DN 5

Required accessories connection coupling type VK 10 not included.

Speed range

- High speed

Types of mixing

- Homogenising
- Dispersing
- Heat exchange
- Suspending



Type	PLR 11	PLR 11 T	PLR 11 GA
Power output	200 Watt	200 Watt	200 Watt
Volume	30 L	30 L	30 L
Viscosity	50000 mPas	50000 mPas	50000 mPas
Torque	3.5 Nm	3.5 Nm	3.5 Nm
No-load speed	1900 rpm	1800 rpm	1300 rpm
Minimum operation speed	500 rpm	500 rpm	500 rpm
ATEX	Ex II 2G Ex h IIC T5 Gb	Ex II 2G Ex h IIC T5 Gb	Ex II 2G Ex h IIC T5 Gb
Code-No.	40 26446 00251 0	40 26446 00253 4	40 26446 00481 1

Viscosity data to be considered as guidelines. All technical data pertaining to 6 bar.

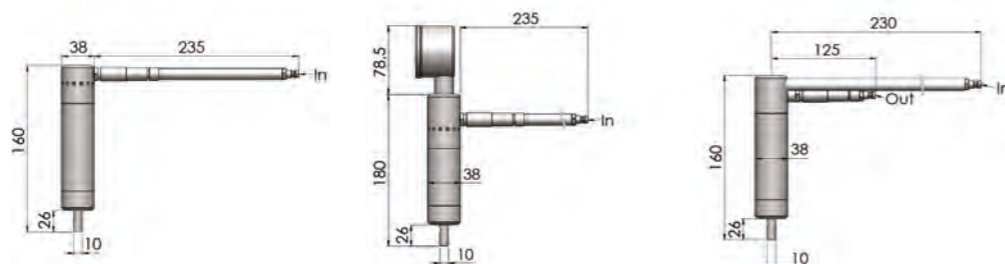

All dimensions in mm.

Standard design

Used compressed air can escape freely via exhaust air holes on the housing. No additional connections for an exhaust air duct are required.

T design

The T models are equipped with an analogue speed display and simplify reproducible stirring processes with the same speed.



Type	PLR 11 T GA	PMR 11 GA	PMR 11T GA
Power output	200 Watt	200 Watt	200 Watt
Volume	30 L	30 L	30 L
Viscosity	50000 mPas	50000 mPas	50000 mPas
Torque	3.5 Nm	3.5 Nm	3.5 Nm
No-load speed	1200 rpm	1300 rpm	1300 rpm
Minimum operation speed	500 rpm	500 rpm	500 rpm
ATEX	Ex II 2G Ex h IIC T5 Gb	Ex II 2G Ex h IIC T5 Gb	Ex II 2G Ex h IIC T5 Gb
Code-No.	40 26446 00486 6	40 26446 00603 7	40 26446 00578 8

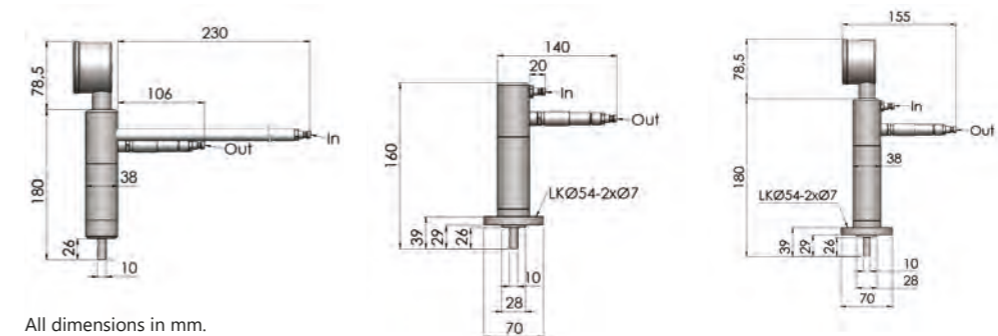

All dimensions in mm.

GA design

GA models feature a separate outlet connection for ducting the exhaust air which leads to improved performance at low speed and results in reduced noise levels. Discharging the exhaust air also enables the use in clean rooms.

Compressed air laboratory stirrers PLR 12 model series

General specifications

- All-stainless steel housing
- Operating pressure 3-6 bar
- Air consumption 260 L/min. at 6 bar
- Clockwise rotation
- ATEX certification

Basic models include

- Continuously adjustable speed control valve
- Support arm Ø 14 mm
- Plug-in connector for DN 5

Required accessories connection coupling type VK 10 not included.

Speed range

Medium to high

Types of mixing

- Homogenising
- Heat exchange
- Suspending



Type	PLR 12	PLR 12 T	PLR 12 GA
Power output	200 Watt	200 Watt	200 Watt
Volume	30 L	30 L	40 L
Viscosity	70000 mPas	70000 mPas	70000 mPas
Torque	5.3 Nm	5.3 Nm	5.3 Nm
No-load speed	1000 rpm	950 rpm	750 rpm
Minimum operation speed	200 rpm	200 rpm	200 rpm
ATEX	Ex II 2G Ex h IIC T5 Gb	Ex II 2G Ex h IIC T5 Gb	Ex II 2G Ex h IIC T5 Gb
Code-No.	40 26446 00260 2	40 26446 00261 9	40 26446 00482 8

Viscosity data to be considered as guidelines. All technical data pertaining to 6 bar.

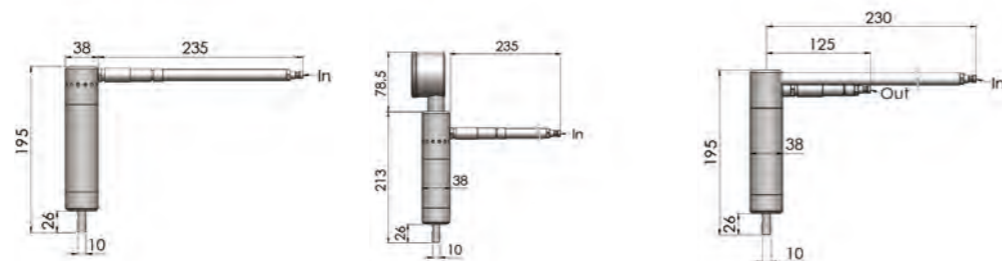

All dimensions in mm.

Standard design

Used compressed air can escape freely via exhaust air holes on the housing. No additional connections for an exhaust air duct are required.

T design

The T models are equipped with an analogue speed display and simplify reproducible stirring processes with the same speed.



Type	PLR 12 T GA	PMR 12 GA	PMR 12T GA
Power output	200 Watt	200 Watt	200 Watt
Volume	40 L	40 L	40 L
Viscosity	70000 mPas	70000 mPas	70000 mPas
Torque	5.3 Nm	5.3 Nm	5.3 Nm
No-load speed	750 rpm	700 rpm	700 rpm
Minimum operation speed	200 rpm	200 rpm	200 rpm
ATEX	Ex II 2G Ex h IIC T5 Gb	Ex II 2G Ex h IIC T5 Gb	Ex II 2G Ex h IIC T5 Gb
Code-No.	40 26446 00487 3	40 26446 00612 9	40 26446 00579 5

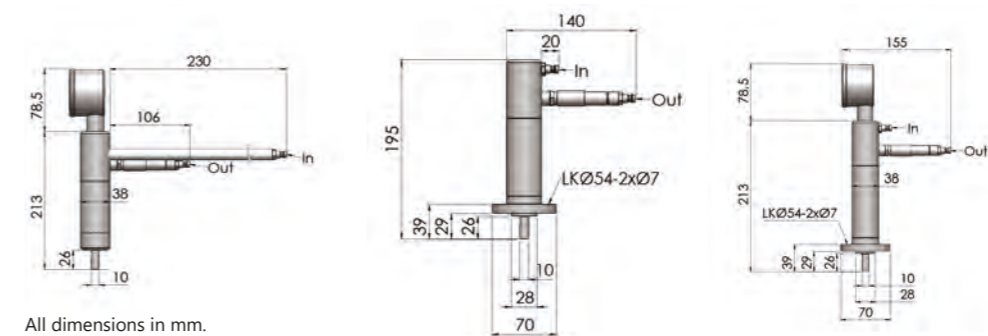

All dimensions in mm.

GA design

GA models feature a separate outlet connection for ducting the exhaust air which leads to improved performance at low speed and results in reduced noise levels. Discharging the exhaust air also enables the use in clean rooms.

Compressed air laboratory stirrers PLR 28 model series

General specifications

- All-stainless steel housing
- Operating pressure 3-6 bar
- Air consumption 260 L/min. at 6 bar
- Clockwise rotation
- ATEX certification

Basic models include

- Continuously adjustable speed control valve
- Support arm Ø 14 mm
- Plug-in connector for DN 5

Required accessories connection coupling type VK 10 not included.

Speed range

Low to medium

Types of mixing

- Homogenising
- Heat exchange
- Suspending



Type	PLR 28	PLR 28 T	PLR 28 GA
Power output	200 Watt	200 Watt	200 Watt
Volume	30 L	30 L	40 L
Viscosity	100000 mPas	100000 mPas	100000 mPas
Torque	10.4 Nm	10.4 Nm	10.4 Nm
No-load speed	580 rpm	550 rpm	450 rpm
Minimum operation speed	100 rpm	100 rpm	100 rpm
ATEX	Ex II 2G Ex h IIC T5 Gb	Ex II 2G Ex h IIC T5 Gb	Ex II 2G Ex h IIC T5 Gb
Code-No.	40 26446 00364 7	40 26446 00365 4	40 26446 00483 5

Viscosity data to be considered as guidelines. All technical data pertaining to 6 bar.

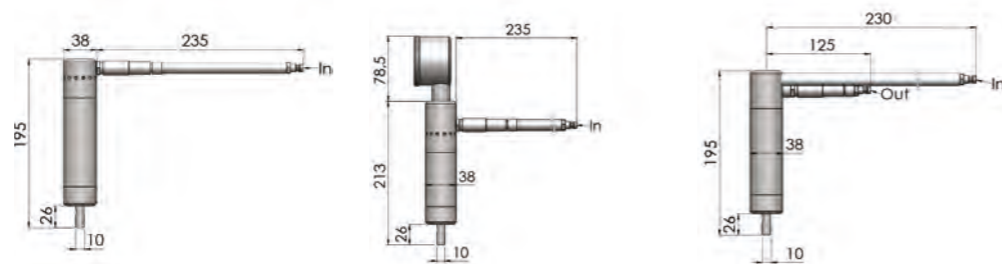

All dimensions in mm.

Standard design

Used compressed air can escape freely via exhaust air holes on the housing. No additional connections for an exhaust air duct are required.

T design

The T models are equipped with an analogue speed display and simplify reproducible stirring processes with the same speed.



Type	PLR 28 T GA	PMR 28 GA	PMR 28T GA
Power output	200 Watt	200 Watt	200 Watt
Volume	40 L	40 L	40 L
Viscosity	100000 mPas	100000 mPas	100000 mPas
Torque	10.4 Nm	10.4 Nm	10.4 Nm
No-load speed	400 rpm	500 rpm	500 rpm
Minimum operation speed	100 rpm	100 rpm	100 rpm
ATEX	Ex II 2G Ex h IIC T5 Gb	Ex II 2G Ex h IIC T5 Gb	Ex II 2G Ex h IIC T5 Gb
Code-No.	40 26446 00488 0	40 26446 00771 3	40 26446 00773 7

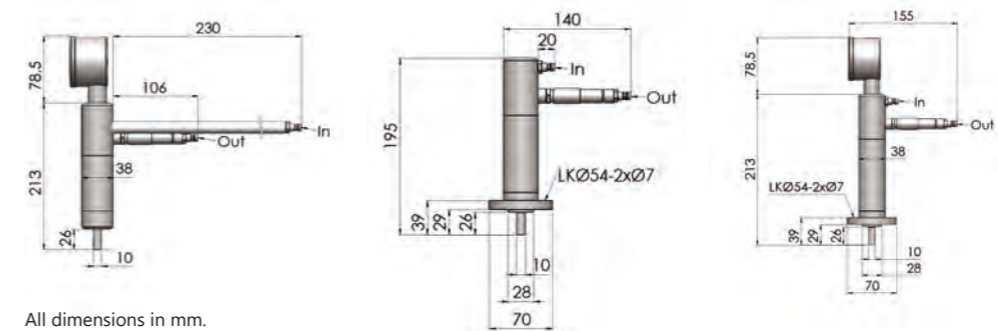

All dimensions in mm.

GA design

GA models feature a separate outlet connection for ducting the exhaust air which leads to improved performance at low speed and results in reduced noise levels. Discharging the exhaust air also enables the use in clean rooms.

BuddeMix Stirring System

Types of mixing

- Homogenising
- Suspending
- Heat exchange

Flow type

Dynamic flow

Characteristics

No shear forces, little air inclusion

Speed range

Low to medium speed

Viscosity range

Low to high viscosity fluids

Suitable stirrers

PLR 11, PLR 12, PLR 28 model series with connection couplings VK 10 x 8 (BuddeMix 30) and connection couplings VK 10 x 10 (Buddemix 1 - 4)

PLM 38/580, PLM 38/260 model series with connection couplings VK 12 x 10

Type	Material	Length	Stirrer Ø	Shaft Ø	Code-No.
BuddeMix Mini 30	1.4404	350 mm	35 mm	8 mm	40 26446 00806 2
BuddeMix 1	1.4404	350 mm	60 mm	10 mm	40 26446 00799 7
BuddeMix 2	1.4404	350 mm	80 mm	10 mm	40 26446 00535 1
BuddeMix 3	1.4404	550 mm	120 mm	10 mm	40 26446 00536 8
BuddeMix 4	1.4404	850 mm	150 mm	10 mm	40 26446 00537 5



BuddeMix 1-4



BuddeMix Mini 30



These pictures show the function of the BuddeMix. Its special stirring geometry ensures an excellent mixing effect, even at slow speeds. This results in gentle, low-shear mixing of media. The BuddeMix stirrer system is available for use with volumes up to 20,000 litres.

Diagonal blade stirring rotors PSR

Types of mixing

- Homogenising
- Suspending
- Dispersing

Flow type

Axial, turbulent

Characteristics

High energy input, high shear forces

Speed range

Medium to high speed operations

Suitable stirrers

PLR 10, PLR 11, PLR 12 model series with connection couplings VK 10
PLM 38/1180 model series with connection couplings VK 12



Type	Material	Length	Stirrer Ø	Shaft Ø	Code-No.
PSR 1	1.4404	350 mm	50 mm	8 mm	40 26446 00115 5
PSR 1	1.4404	550 mm	50 mm	10 mm	40 26446 00740 9
PSR 3	1.4404	550 mm	100 mm	10 mm	40 26446 00796 6

Anchor stirring rotors AR

Types of mixing

- Homogenising
- Heat exchange

Flow type

Tangential, laminar

Characteristics

Operates at slow rotation speed, with low distance to the container wall

Speed range

Low to medium speed operations

Viscosity range

High to medium viscosity fluids

Suitable stirrers

PLR 12, PLR 28 model series with connection couplings VK 10 x 10
PLM 38/580 and PLM 38/260 model series with connection couplings VK 12 x 10



Type	Material	Length	Stirrer Ø	Shaft Ø	Code-No.
AR 1	1.4404	500 mm	80 mm	10 mm	40 26446 00793 5
AR 2	1.4404	500 mm	100 mm	10 mm	40 26446 00794 2
AR 3	1.4404	500 mm	150 mm	10 mm	40 26446 00795 9

We adapt the **shaft length** of our stirring tools to **your requirements** on request.

Please contact us for an individual consultation.

Propeller stirring rotors PR

Types of mixing

- Homogenising
- Suspending
- Dispersing

Flow type

Axial

Characteristics

High energy input, medium to high shear forces

Speed range

Medium to high speed operations

Suitable stirrers

PLR 10, PLR 11, PLR 12 model series with connection couplings VK 10

PLM 38/1180 and PLM 38/580 model series with connection couplings VK 12

Type	Material	Length	Stirrer Ø	Shaft Ø	Stirrer Head	Code-No.
PR 1	1.4404	350 mm	45 mm	8 mm	Blasted	40 26446 00123 0
PR 3	1.4404	550 mm	140 mm	10 mm	E Polish	40 26446 00125 4
PR 4	1.4404	850 mm	140 mm	10 mm	E Polish	40 26446 00126 1
PR 5	1.4404	550 mm	75 mm	10 mm	Blasted	40 26446 00766 9
PR 6	1.4404	550 mm	100 mm	10 mm	Blasted	40 26446 00980 9



PR 1,5,6



PR 3,4



Dissolver stirring rotors DS

Types of mixing

- Dispersing

Flow type

Radial, turbulent

Characteristics

High speed rotor, high energy input, high shear forces

Speed range

High to very high speed operations

Viscosity range

Low to medium viscosity fluids

Suitable stirrers

PLR 10, PLR 11, PLR 12 model series

PLM 38/1180 model series

Suitable connection couplings

DS 1: VK 10 x 8 (for PLR stirrers)

DS 2-6: VK 10 x 10 (for PLR stirrers), VK 12 x 10 (for PLM stirrers)

Type	Material	Length	Stirrer Ø	Shaft Ø	Code-No.
DS 1	1.4404	350 mm	30 mm	8 mm	40 26446 00109 4
DS 2	1.4404	350 mm	40 mm	10 mm	40 26446 00800 0
DS 3	1.4404	550 mm	50 mm	10 mm	40 26446 00677 8
DS 4	1.4404	550 mm	60 mm	10 mm	40 26446 00801 7
DS 5	1.4404	550 mm	70 mm	10 mm	40 26446 00802 4
DS 6	1.4404	550 mm	80 mm	10 mm	40 26446 00735 5



DS 1



DS 6



Creation of a fluid-fluid dispersion (oil in water)

Propeller stirring rotors, PTFE-coated

Types of mixing

- Homogenising
- Suspending

Flow type

Axial

Characteristics

High energy input, medium shear forces, superior chemical resistance

Speed range

Medium to high speed operations

Suitable stirrers

PLR 11, PLR 12, PLR 28 model series with connection coupling VK 10 x 8

PLM 38/1180 and PLM 38/580 model series with connection coupling VK 12 x 8

PM 64 model series with connection coupling VK 14 x 8

Type	Material	Length	Shaft Ø	To fit chuck	Paddle width	Paddle Ø	Code-No.
PRP 1	PTFE	600 mm	10 mm	8 mm	3 mm	75 mm	40 26446 00380 7
PRP 2	PTFE	600 mm	10 mm	8 mm	4 mm	140 mm	40 26446 00982 3



PRP 1



PRP 2

We adapt the **shaft length** of our stirring tools to **your requirements** on request.
Please contact us for an individual consultation.

Connection couplings VK



Fixed-diameter connection between motor and stirring shafts. Suitable for use in potentially explosive atmospheres (ATEX). Suitable for all PLR models.

Type	Description	Material	Receiver Ø	To fit shaft Ø	Code-No.
VK 10 x 6	Connection coupling	1.4404	10 x 6 mm	6 mm	40 26446 00745 6
VK 10 x 8	Connection coupling	1.4404	10 x 8 mm	8 mm	40 26446 00742 3
VK 10 x 10	Connection coupling	1.4404	10 x 10 mm	10 mm	40 26446 00741 6

Flexible glass stirring shaft couplings PK



Colour may vary

For stirring tasks using glass stirring rods. Provides precise alignment of motor and shaft and evens out axial and height differences. Shaft clamping width 6 to 10 mm.

Type	Receiver drive side	To fit shaft Ø	Length	Code-No.
PK 10	i.d. Ø 10 mm	6 - 10 mm	80 mm	40 26446 00058 5
PK 10/13	i.d. Ø 10/13 mm	6 - 10 mm	80 mm	40 26446 00059 2

Flexible glass stirring shaft couplings K

Tension-free connection of glass stirrer shafts with a suitable stirrer guide (not included with delivery). Shaft clamping width 6 to 10 mm.



K 10, K10/13



FK 1

Type	Receiver drive side	To fit shaft Ø	Length	Code-No.
K 10	i.d. Ø 10 mm	6 - 10 mm	105 mm	40 26446 00054 7
K 10/13	i.d. Ø 10/13 mm	6 - 10 mm	105 mm	40 26446 00055 4
FK 1	with stud Ø 8 mm	6 - 10 mm	108 mm	40 26446 00595 5

Motor oil

LT-Oil

Fully synthetic food grade oil according to NSF H1, FDA 21 CFR 178.3570.
Viscosity class 32.
Operating temperature -45°C to +135°C.

Oil

Resin-free and non-corrosive oil for lubrication of compressed air stirrers.
Viscosity class 32.



Type	Description	Code-No.
LT-Oil	Food grade oil 500 ml	40 26446 00955 7
Oil	Cylinder oil 500 ml	40 26446 00081 3

Stands

Floor stand BS

With angled foot, powder-coated or stainless steel, side length 500 mm, stainless steel rod Ø 34 mm.

Retort stand PS

PS1: Powder-coated steel base 210 x 315 mm, stainless steel rod Ø 14 mm.
PS2: Stainless steel base 210 x 315 mm, stainless steel rod Ø 14 mm.

Type	Description	Length	Code-No.
BS 1	Plastic coating / stainless steel	1000 mm	40 26446 00086 8
BS 2	Plastic coating / stainless steel	1500 mm	40 26446 00083 7
BS 3	All in stainless steel	1000 mm	40 26446 00826 0
PS 1	Powder-coated / stainless steel	1000 mm	40 26446 00324 1
PS 2	All in stainless steel	1000 mm	40 26446 00979 3



BS1 and BS2



BS3



PS1 and PS2



Our compressed air stirrers are **explosion-protected** according to the current **ATEX regulation**.

Heating bath liquid BUDE

BUDE heating bath liquid has a high flash point, is stable at high temperatures and can therefore be used continuously as a heating medium up to approx. 170°C. Higher temperatures (below flash point) are possible for a short period, but will result in rapid darkening.

- Accidental spillage of water into the bath does not lead to dangerous spitting at temperatures over 100°C, as the water dissolves in the heating bath liquid and subsequently evaporates safely
- BUDE heating bath liquid can easily be rinsed away with water which eases cleaning of laboratory equipment, e.g. distillation flasks, and also bench or floor if the bath liquid is accidentally spilled.
- BUDE heating bath liquid does not foam when mixed with water.
- The low pour point allows the bath liquid also to be used as a cooling medium. Mixtures with 10% to 30% water have proved best for this.

Chemical character

Modified polyglycol ether

Appearance

Clear, colourless to lightly yellowish liquid

Storage time

In the original, unopened containers unlimited storage time. When stored for long periods of more than 2 years, the product may become darker. This does not affect the performance of the product.

Density (DIN 51757, ASTM 1298, 23°C)

1.13 - 1.17 g/cm³

Flashpoint to DIN EN ISO 2592

> 290°C

Water solubility

Can be mixed with water at any ratio. The hardness of the water has no effect on the bath liquid.



Type	Code-No.
Heating bath liquid BUDE	40 26446 00385 2

CUSTOM-MADE

We will be pleased to provide you with customised solutions according to your specifications. Please contact us for an individual consultation – we will find the best possible solution for your stirring process.



Bossheads

Bosshead KR 260

Clamping width 10 to 36 mm

Stainless steel bosshead KR 360

Bosshead with prism clamping on both sides, clamping range 12 to 36 mm, heavy design all in stainless steel.

Bosshead KK-16, swivelling

Clamping width 16 mm

Type	Code-No.
KR 260	40 26446 00386 9
KR 360	40 26446 00815 4
KK-16	40 26446 00325 8



Example assembly



KR 260



KR 360



KK-16

Clamp holder SP

With bosshead KR 260, strap length 150 cm.



Type	Description	Code-No.
SP	Clamp holder with bosshead KR 260	40 26446 00792 8

Stirring shaft protection RWS

Prevents injuries from rotating stirrers during use. Length adjustable 190-310 mm, incl. support arm L=275 mm. Bosshead not included.



Type	Description	Code-No.
RWS	Stirring shaft protection	40 26446 00095 0

Service unit type WE

The service unit with filter, regulator and lubricator function provides both clean air with the recommended air purity class at the output and lubrication of motors.

2-piece combination consisting of filter pressure regulator and compressed air lubricator, pneumatic connection 1/4", filter porosity 40 µm, nominal flow rate 1600 l/min, with plastic bowls.



Type	Description	Code-No.
WE	Service unit	40 26446 00935 9

Finger-operated oiler OT

For manual lubrication of compressed air coming into the motor. Pneumatic connection 1/4".



Type	Description	Code-No.
ÖT	Finger-operated oiler	40 26446 00047 9

PHARMA/FOOD GRADE STIRRERS



The PLM series offers optimal stirrers for a variety of mixing tasks in the laboratory, pilot plants and in production under explosion-protected conditions. PLM compressed air stirrers are specially designed for use in the pharmaceutical and food industry. Pneumatic PLM series stirrers can be operated without lubrication and are fitted with an FDA-compliant shaft seal. PLM pharma stirrers are offered in 3 different versions for all kinds of stirring tasks at various viscosities.

PLM pharma/food grade stirrers are suitable for stirring volumes from 60 to 500 liters and feature an exhaust air ducting for operation e.g. in clean rooms and/or isolators.

We offer special designs tailored to your wishes, e.g. special flange or TriClamp connections. Our choice of specialised stirring rotor shafts and accessories together with our compressed air stirrers offers the optimal solution for your stirring process.

All our stirrers are certified to ATEX regulation II 2G Ex h IIC T5 Gb.

Our pharma/food grade stirrers are specially adapted to the requirements of the pharmaceutical, cosmetics and food industries.

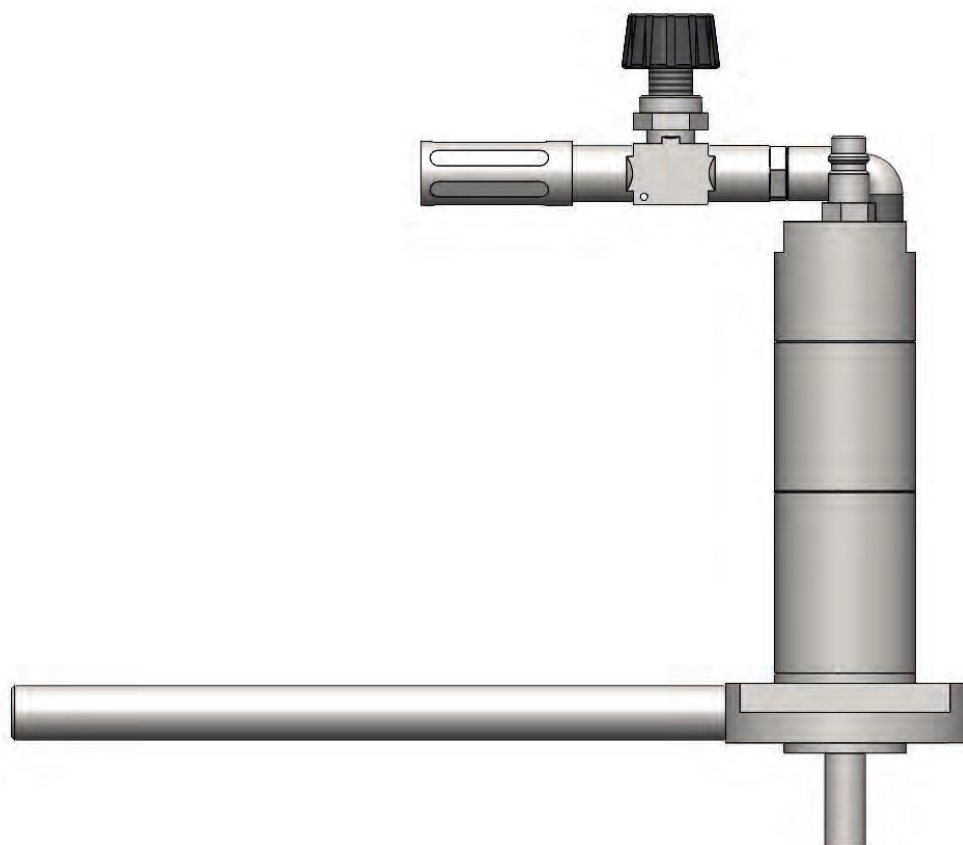

Volume



Volume up to 500 litres

Custom made



We offer custom designs, tailored individually to your requirements

ATEX certification



Our pharma-/food grade stirrers are explosion-protected according to the current ATEX regulation



Compressed air pharma/food grade stirrers model series PLM 38/1180

General specifications

- All-stainless steel housing
- Operating pressure 3-6 bar
- Air consumption 500 L/min. at 6 bar
- Clockwise rotation
- ATEX certification
- Sealing ring conform to FDA regulations



Types of mixing

- Homogenising
- Suspending
- Dispersing

Speed range

- Medium to high

Basic models include

- Continuously adjustable speed control valve
- Support arm Ø 16 mm to fit on a stand
- Flange Ø 73 mm, bolt circle Ø 55 mm - 2x Ø 6.5 mm
- Plug-in connector for DN 7.4 / 7.8
- Silencer

Required accessories connection coupling VK 12 not included.



Type	PLM 38/1180
Power output	380 Watt
Volume	200 L
Viscosity	10000 mPas
No-load speed	1180 rpm
Minimum operation speed	400 rpm
Torque	6.3 Nm
ATEX	Ex II 2G Ex h IIC T5 Gb
Code-No.	40 26446 00376 0

Viscosity data to be considered as guidelines. All technical data pertaining to 6 bar.

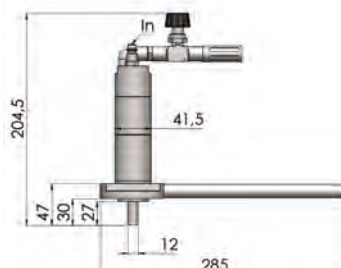

All dimensions in mm.

Compressed air pharma/food grade stirrers model series PLM 38/580

General specifications

- All-stainless steel housing
- Operating pressure 3-6 bar
- Air consumption 500 L/min. at 6 bar
- Clockwise rotation
- ATEX certification
- Sealing ring conform to FDA regulations



Types of mixing

- Homogenising
- Suspending
- Heat exchange

Speed range

- Low to medium

Basic models include

- Continuously adjustable speed control valve
- Support arm Ø 16 mm to fit on a stand
- Flange Ø 73 mm, bolt circle Ø 55 mm - 2x Ø 6.5 mm
- Plug-in connector for DN 7.4 / 7.8
- Silencer

Required accessories connection coupling VK 12 not included.



Type	PLM 38/580
Power output	380 Watt
Volume	500 L
Viscosity	50000 mPas
No-load speed	580 rpm
Minimum operation speed	200 rpm
Torque	8.6 Nm
ATEX	Ex II 2G Ex h IIC T5 Gb
Code-No.	40 26446 00375 3

Viscosity data to be considered as guidelines. All technical data pertaining to 6 bar.

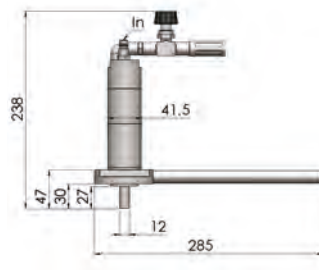

All dimensions in mm.

Compressed air pharma/food grade stirrers model series PLM 38/260

General specifications

- All-stainless steel housing
- Operating pressure 3-6 bar
- Air consumption 500 L/min. at 6 bar
- Clockwise rotation
- ATEX certification
- Sealing ring conform to FDA regulations



Types of mixing

- Homogenising
- Suspending
- Heat exchange

Speed range

- Low

Basic models include

- Continuously adjustable speed control valve
- Support arm Ø 16 mm to fit on a stand
- Flange Ø 73 mm, bolt circle Ø 55 mm - 2x Ø 6.5 mm
- Plug-in connector for DN 7.4 / 7.8
- Silencer

Required accessories connection coupling VK 12 not included.



Type	PLM 38/260
Power output	380 Watt
Volume	500 L
Viscosity	100000 mPas
No-load speed	260 rpm
Minimum operation speed	100 rpm
Torque	19 Nm
ATEX	Ex II 2G Ex h IIC T5 Gb
Code-No.	40 26446 00374 6

Viscosity data to be considered as guidelines. All technical data pertaining to 6 bar.

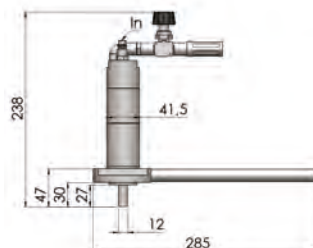

All dimensions in mm.

BuddeMix Stirring System



Types of mixing

- Homogenising
- Suspending
- Heat exchange

Flow type

Dynamic flow

Characteristics

No shear forces, little air inclusion, for low to high viscosity fluids

Speed range

Low to medium speed operations

Suitable stirrers

Model series PLM 38/580, PLM 38/260

Model series PM 64/30, PM 64/65

Suitable connection couplings

BuddeMix 5 und 6

VK 12 x 12 (PLM model series), VK 14 x 12 (PM model series)

BuddeMix 7

VK 14 x 12 (PLM model series), VK 14 x 14 (PM model series)

Type	Material	Length	Stirrer Ø	Shaft Ø	Code-No.
BuddeMix 5	1.4404	550 mm	150 mm	12 mm	40 26446 00528 3
BuddeMix 6	1.4404	550 mm	170 mm	12 mm	40 26446 00529 0
BuddeMix 7	1.4404	850 mm	210 mm	14 mm	40 26446 00530 6



These pictures show the function of the BuddeMix. Its special stirring geometry ensures an excellent mixing effect, even at slow speeds. This results in gentle, low-shear mixing of media. The BuddeMix stirrer system is available for use with volumes up to 20,000 litres.



Our compressed air stirrers are **explosion-protected** according to the current **ATEX regulation**.

Connection couplings VK

Fixed-diameter connection between motor and stirring shafts. Suitable for use in potentially explosive atmospheres (ATEX). Suitable for all PLM models.



Type	Description	Material	Receiver Ø	To fit shaft Ø	Code-No.
VK 12 x 10	Connection couplings VK	1.4404	12 x 10 mm	10 mm	40 26446 00525 2
VK 12 x 12	Connection couplings VK	1.4404	12 x 12 mm	12 mm	40 26446 00526 9
VK 12 x 14	Connection couplings VK	1.4404	12 x 14 mm	14 mm	40 26446 00647 1

Stands

Floor stand BS

With angled foot, powder-coated or stainless steel, side length 500 mm, stainless steel rod Ø 34 mm.

Type	Description	Length	Code-No.
BS 1	Plastic coating / stainless steel	1000 mm	40 26446 00086 8
BS 2	Plastic coating / stainless steel	1500 mm	40 26446 00083 7
BS 3	All in stainless steel	1000 mm	40 26446 00826 0



BS1 and BS2



BS3

Clamp holder SP

With bosshead KR 260, strap length 150 cm.



Type	Description	Code-No.
SP	Clamp holder with bosshead KR 260	40 26446 00792 8

Bossheads

Bosshead KR 260

Clamping width 10 to 36 mm.

Stainless steel bosshead KR 360

Bosshead with prism clamping on both sides, clamping range 12 to 36 mm, heavy design all in stainless steel.

Type	Code-No.
KR 260	40 26446 00386 9
KR 360	40 26446 00815 4



KR 260



KR 360

Motor oil for the food industry



Fully synthetic food grade oil according to NSF H1, FDA 21 CFR 178.3570.
Viscosity class 32.
Operating temperature -45°C to +135°C.

Type	Description	Code-No.
LT-Oil	Food grade oil 500 ml	40 26446 00955 7

Service unit type WE

The service unit with filter, regulator and lubricator function provides both clean air with the recommended air purity class at the output and lubrication of motors.

2-piece combination consisting of filter pressure regulator and compressed air lubricator, pneumatic connection 1/4", filter porosity 40 µm, nominal flow rate 1600 l/min, with plastic bowls.



Type	Description	Code-No.
WE	Service unit	40 26446 00935 9

INDUSTRIAL STIRRERS



The PM series offers optimal stirrers for a variety of mixing tasks in pilot plants and in production under explosion-protected conditions. A broad selection of different model variants covers the requirements for all mixing tasks in a wide range of viscosities.

Our PM industrial stirrers are suitable for stirring volumes from 60 to 1500 liters. Pneumatic PM series stirrers can run dry without using any lubrication, on request equipped with an FDA-compliant shaft seal (back-to-back-seal). All PM series stirrers feature an exhaust air ducting and can be used in clean room conditions and/or isolators.

A variety of assembly options provides the suitable stirrer for every container. We offer special designs tailored to your wishes, e.g. special flange or TriClamp connections.

Our choice of specialised stirring rotor shafts and accessories together with our compressed air industrial stirrers offers the optimal solution for your stirring process.

All our stirrers are certified to ATEX regulation II 2G Ex h IIC T5 Gb.

Area of application: Paints and coatings industry, chemical industry, pharmaceutical industry, cosmetics industry, food industry.

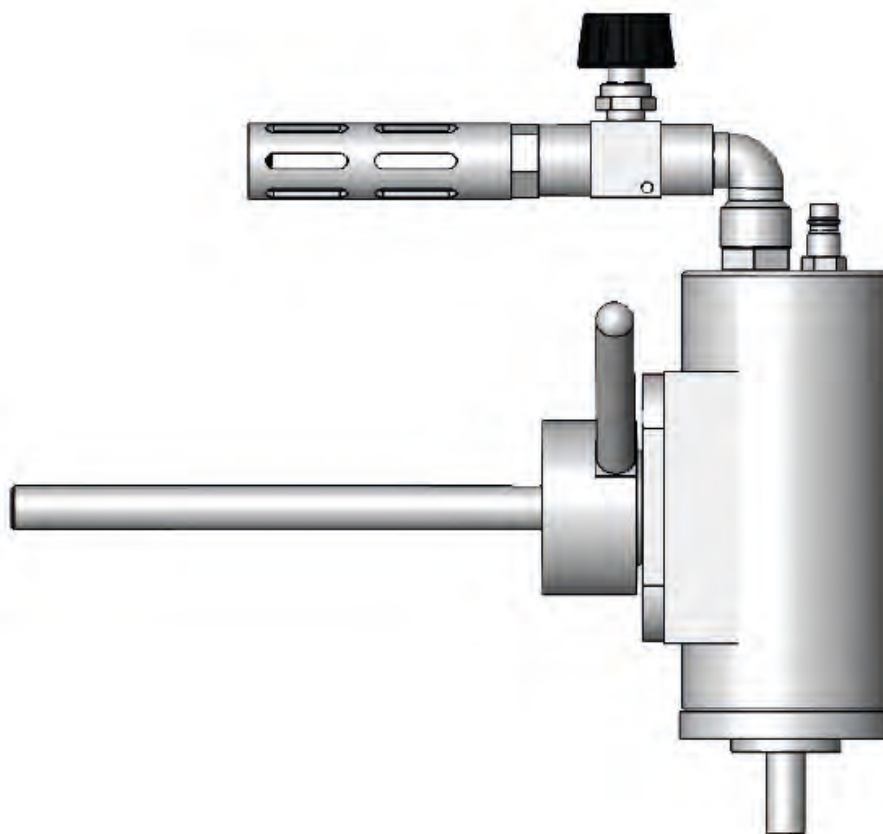

Volume



Volume up to 1500 litres

Custom made



We offer custom designs, tailored individually to your requirements

ATEX certification



Our industrial stirrers are explosion-protected according to the current ATEX regulation

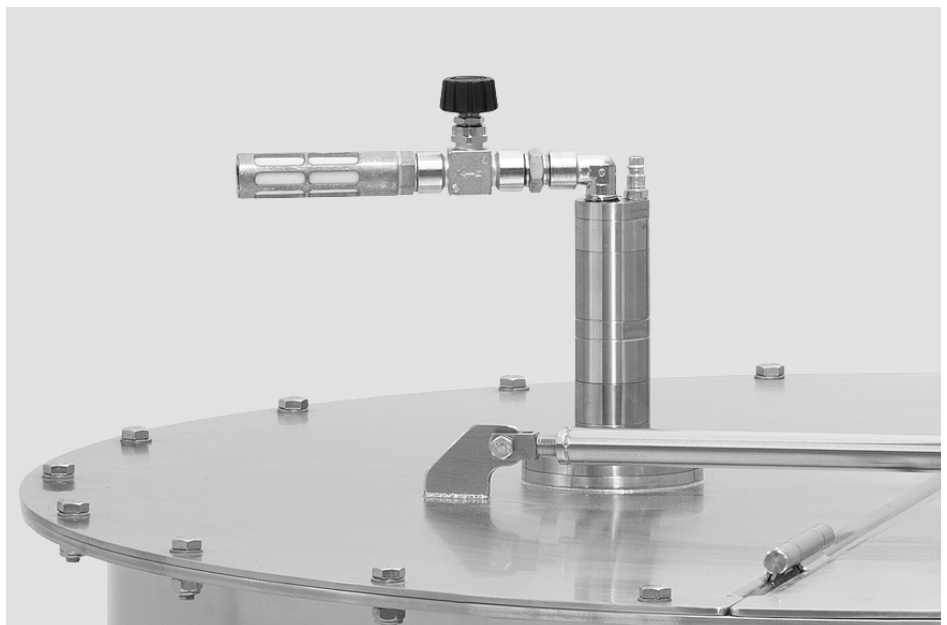

Compressed air industrial stirrers model series PM 64/160

General specifications

- All-stainless steel housing
- Operating pressure 3-6 bar
- Air consumption 800 L/min. at 6 bar
- Clockwise rotation
- ATEX certification

Basic models include

- Continuously adjustable speed control valve
- Plug-in connector for DN 7.8
- Silencer
- Support arm Ø16 mm x 200 mm



Speed range

High to very high

Types of mixing

- Homogenising
- Dispersing
- Suspending



Type	PM 64/160-A-V	BSR 64/160-A-V	WSR 64/160-A-V
Description	With swivel support arm	With floor stand	With wall bracket
Power output	640 Watt	640 Watt	640 Watt
Volume	200 L	200 L	200 L
Viscosity	20000 mPas	20000 mPas	20000 mPas
No-load speed	1600 rpm	1600 rpm	1600 rpm
Minimum operation speed	600 rpm	600 rpm	600 rpm
Torque	4.7 Nm	4.7 Nm	4.7 Nm
ATEX	Ex II 2G Ex h IIC T5 Gb	Ex II 2G Ex h IIC T5 Gb	Ex II 2G Ex h IIC T5 Gb
Code-No.	40 26446 00492 7	40 26446 00494 1	40 26446 00497 2

Type	AFR 64/160-V	PM 64/160-V
Description	With screwthread device	With circular flange
Power output	640 Watt	640 Watt
Volume	200 L	200 L
Viscosity	20000 mPas	20000 mPas
No-load speed	1600 rpm	1600 rpm
Minimum operation speed	600 rpm	600 rpm
Torque	4.7 Nm	4.7 Nm
ATEX	Ex II 2G Ex h IIC T5 Gb	Ex II 2G Ex h IIC T5 Gb
Code-No.	40 26446 00503 0	40 26446 00506 1

All technical data pertaining to 6 bar. Viscosity data to be considered as guidelines.

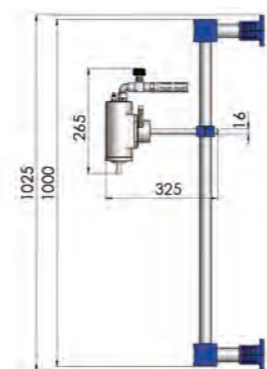
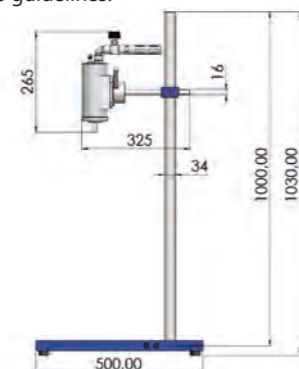
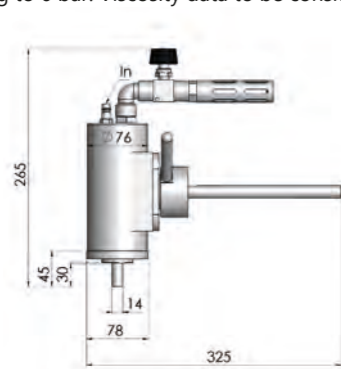

All dimensions in mm.

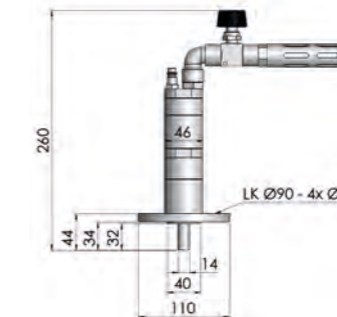
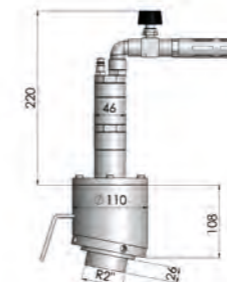

A-V models

Stirrers of the A-V series come with a swivel support arm of Ø 16 mm. The device allows an easy and flexible orientation of the stirrer in any desired angle for different types of containers, e.g. drums, buckets, canisters.

BSR models

BSR floor stand stirrers are additionally supplied with the floor stand type BS1 and a stable bosshead type KR 360. BSR stirrers perform mixing tasks up to a volume of 200 L.

WSR models

WSR wall bracket stirrers come with a stable wall mount and a bosshead type KR 360, heavy design all in stainless steel. Enhanced flexibility and space-saving alternative for classic stands.

AFR models

AFR series stirring units are fitted with a 2" bunghole adapter to unscrew on 200 L DIN standard industrial drums and a connection coupling VK 14x14 mm. Suitable swing-out stirring system BuddeMix SW 4 (please order separately) is especially suitable for small openings and unfolds to a diameter of 300 mm for a most effective mixing result.

V models

Stirrers of the V series include a 4-hole circular flange to be mounted directly onto a container lid or a suitable container crossbeam.

Compressed air industrial stirrers model series PM 64/65

General specifications

- All-stainless steel housing
- Operating pressure 3-6 bar
- Air consumption 800 L/min. at 6 bar
- Clockwise rotation
- ATEX certification

Basic models include

- Continuously adjustable speed control valve
- Plug-in connector for DN 7.8
- Silencer
- Support arm Ø16 mm x 200 mm



Speed range

Medium to high

Types of mixing

- Homogenising
- Heat exchange
- Suspending



Type	PM 64/65-A-V	BSR 64/65-A-V	WSR 64/65-A-V
Description	With swivel support arm	With floor stand	With wall bracket
Power output	640 Watt	640 Watt	640 Watt
Volume	200 L	200 L	200 L
Viscosity	50000 mPas	50000 mPas	50000 mPas
No-load speed	650 rpm	650 rpm	650 rpm
Minimum operation speed	200 rpm	200 rpm	200 rpm
Torque	9.4 Nm	9.4 Nm	9.4 Nm
ATEX	Ex II 2G Ex h IIC T5 Gb	Ex II 2G Ex h IIC T5 Gb	Ex II 2G Ex h IIC T5 Gb
Code-No.	40 26446 00491 0	40 26446 00495 8	40 26446 00498 9

Type	AFR 64/65-V	PM 64/65-V
Description	With screwthread device	With circular flange
Power output	640 Watt	640 Watt
Volume	200 L	200 L
Viscosity	50000 mPas	50000 mPas
No-load speed	650 rpm	650 rpm
Minimum operation speed	200 rpm	200 rpm
Torque	9.4 Nm	9.4 Nm
ATEX	Ex II 2G Ex h IIC T5 Gb	Ex II 2G Ex h IIC T5 Gb
Code-No.	40 26446 00504 7	40 26446 00507 8

All technical data pertaining to 6 bar. Viscosity data to be considered as guidelines.

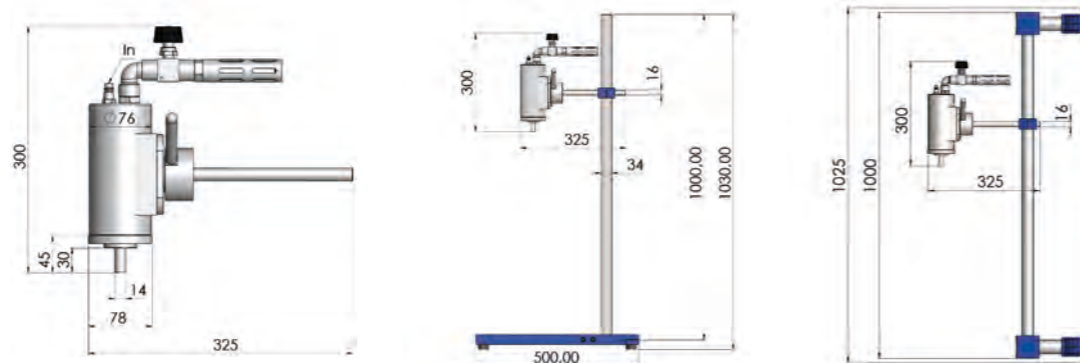

All dimensions in mm.

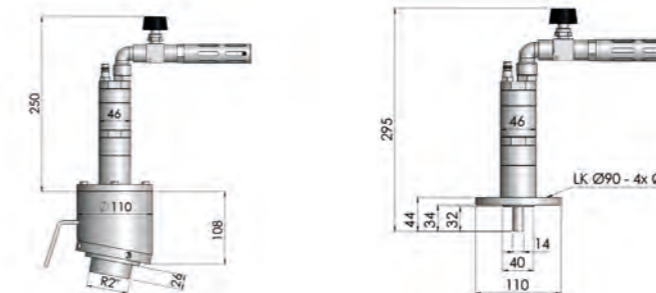

A-V models

Stirrers of the A-V series come with a swivel support arm of Ø 16 mm. The device allows an easy and flexible orientation of the stirrer in any desired angle for different types of containers, e.g. drums, buckets, canisters.

BSR models

BSR floor stand stirrers are additionally supplied with the floor stand type BS1 and a stable bosshead type KR 360. BSR stirrers perform mixing tasks up to a volume of 200 L.

WSR models

WSR wall bracket stirrers come with a stable wall mount and a bosshead type KR 360, heavy design all in stainless steel. Enhanced flexibility and space-saving alternative for classic stands.

AFR models

AFR series stirring units are fitted with a 2" bunghole adapter to unscrew on 200 L DIN standard industrial drums and a connection coupling VK 14x14 mm. Suitable swing-out stirring system BuddeMix SW 4 (please order separately) is especially suitable for small openings and unfolds to a diameter of 300 mm for a most effective mixing result.

V models

Stirrers of the V series include a 4-hole circular flange to be mounted directly onto a container lid or a suitable container crossbeam.

Compressed air industrial stirrers model series PM 64/30

General specifications

- All-stainless steel housing
- Operating pressure 3-6 bar
- Air consumption 800 L/min. at 6 bar
- Clockwise rotation
- ATEX certification

Basic models include

- Continuously adjustable speed control valve
- Plug-in connector for DN 7.8
- Silencer
- Support arm Ø16 mm x 200 mm



Speed range

Low to medium

Types of mixing

- Homogenising
- Heat exchange
- Suspending



Type	PM 64/30-A-V	BSR 64/30-A-V	WSR 64/30-A-V
Description	With swivel support arm	With floor stand	With wall bracket
Power output	640 Watt	640 Watt	640 Watt
Volume	200 L	200 L	200 L
Viscosity	100000 mPas	100000 mPas	100000 mPas
No-load speed	300 rpm	300 rpm	300 rpm
Minimum operation speed	100 rpm	100 rpm	100 rpm
Torque	21 Nm	21 Nm	21 Nm
ATEX	Ex II 2G Ex h IIC T5 Gb	Ex II 2G Ex h IIC T5 Gb	Ex II 2G Ex h IIC T5 Gb
Code-No.	40 26446 00493 4	40 26446 00496 5	40 26446 00499 6

Type	AFR 64/30-V	PM 64/30-V
Description	With screwthread device	With circular flange
Power output	640 Watt	640 Watt
Volume	200 L	500 L
Viscosity	100000 mPas	100000 mPas
No-load speed	300 rpm	300 rpm
Minimum operation speed	100 rpm	100 rpm
Torque	21 Nm	21 Nm
ATEX	Ex II 2G Ex h IIC T5 Gb	Ex II 2G Ex h IIC T5 Gb
Code-No.	40 26446 00505 4	40 26446 00508 5

All technical data pertaining to 6 bar. Viscosity data to be considered as guidelines.

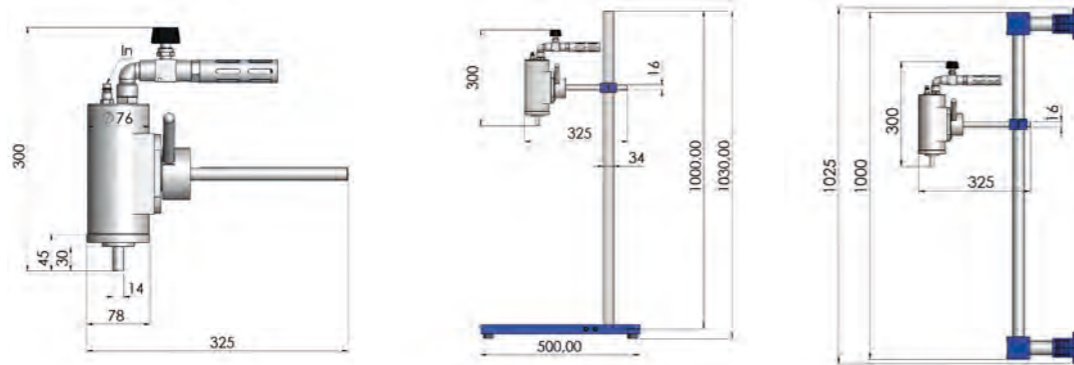

All dimensions in mm.

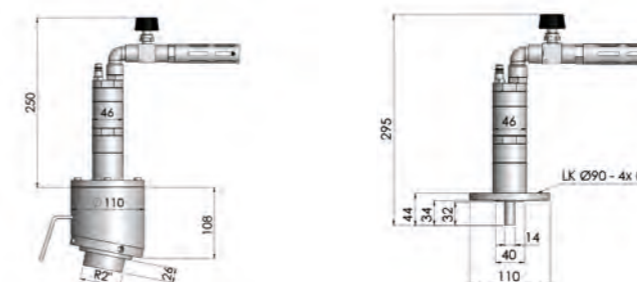

A-V models

Stirrers of the A-V series come with a swivel support arm of Ø 16 mm. The device allows an easy and flexible orientation of the stirrer in any desired angle for different types of containers, e.g. drums, buckets, canisters.

BSR models

BSR floor stand stirrers are additionally supplied with the floor stand type BS1 and a stable bosshead type KR 360. BSR stirrers perform mixing tasks up to a volume of 200 L.

WSR models

WSR wall bracket stirrers come with a stable wall mount and a bosshead type KR 360, heavy design all in stainless steel. Enhanced flexibility and space-saving alternative for classic stands.

AFR models

AFR series stirring units are fitted with a 2" bunghole adapter to unscrew on 200 L DIN standard industrial drums and a connection coupling VK 14x14 mm. Suitable swing-out stirring system BuddeMix SW 4 (please order separately) is especially suitable for small openings and unfolds to a diameter of 300 mm for a most effective mixing result.

V models

Stirrers of the V series include a 4-hole circular flange to be mounted directly onto a container lid or a suitable container crossbeam.

Compressed air industrial stirrers model series PM 120/300

General specifications

- All-stainless steel housing
- Operating pressure 3-6 bar
- Air consumption 1380 L/min. at 6 bar
- Clockwise rotation
- ATEX certification



Basic models include

- Continuously adjustable speed control valve
- Plug-in connector for DN 7.8
- Silencer

Types of mixing

- Homogenising
- Suspending
- Heat exchange

Speed range

- Low to medium



Type	PM 120/300-V
Description	With circular flange
Viscosity	150000 mPas
Power output	1.2 kW
Volume	1500 L
No-load speed	300 rpm
Minimum operation speed	50 rpm
Torque	63 Nm
ATEX	Ex II 2G Ex h IIC T5 Gb
Code-No.	40 26446 00828 4

All technical data pertaining to 6 bar. Viscosity data to be considered as guidelines.

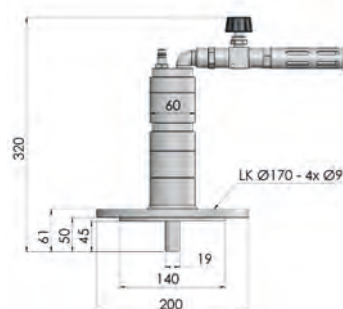

All dimensions in mm.

Compressed air industrial stirrers model series PM 120/600

General specifications

- All-stainless steel housing
- Operating pressure 3-6 bar
- Air consumption 1380 L/min. at 6 bar
- Clockwise rotation
- ATEX certification



Basic models include

- Continuously adjustable speed control valve
- Plug-in connector for DN 7.8
- Silencer

Types of mixing

- Homogenising
- Suspending
- Heat exchange

Speed range

- Low to medium



Type	PM 120/600-V
Description	With circular flange
Viscosity	100000 mPas
Power output	1.2 kW
Volume	1500 L
No-load speed	600 rpm
Minimum operation speed	200 rpm
Torque	38 Nm
ATEX	Ex II 2G Ex h IIC T5 Gb
Code-No.	40 26446 00829 1

All technical data pertaining to 6 bar. Viscosity data to be considered as guidelines.

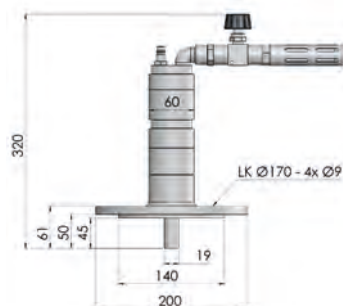

All dimensions in mm.

Compressed air industrial stirrers model series PM 120/1000

General specifications

- All-stainless steel housing
- Operating pressure 3-6 bar
- Air consumption 1380 L/min. at 6 bar
- Clockwise rotation
- ATEX certification



Basic models include

- Continuously adjustable speed control valve
- Plug-in connector for DN 7.8
- Silencer

Types of mixing

- Homogenising
- Suspending
- Heat exchange
- Dispersing

Speed range

- Medium to high



Type	PM 120/1000-V
Description	With circular flange
Viscosity	80000 mPas
Power output	1,2 kW
Volume	1500 L
No-load speed	1000 rpm
Minimum operation speed	400 rpm
Torque	19 Nm
ATEX	Ex II 2G Ex h IIC T5 Gb
Code-No.	40 26446 00830 7

All technical data pertaining to 6 bar. Viscosity data to be considered as guidelines.

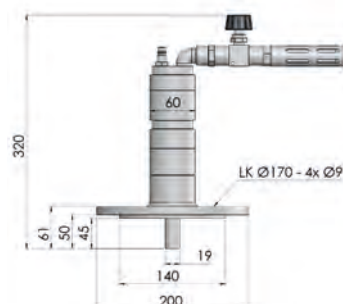

All dimensions in mm.

BuddeMix stirring system

Types of mixing

- Homogenising
- Suspending
- Heat exchange

Flow type

Dynamic flow

Characteristics

No shear forces, little air inclusion, for low to high viscosity fluids

Speed range

Low to medium speed operations

Suitable stirrers

PM 64/30 model series with connection coupling VK 14

PM 120/300 model series and PM 120/600 model series with connection coupling VK 19



Type	Material	Length	Stirrer Ø	Shaft Ø	Code-No.
BuddeMix 5	1.4404	550 mm	150 mm	12 mm	40 26446 00528 3
BuddeMix 6	1.4404	550 mm	170 mm	12 mm	40 26446 00529 0
BuddeMix 7	1.4404	850 mm	210 mm	14 mm	40 26446 00530 6
BuddeMix 8	1.4404	850 mm	320 mm	20 mm	40 26446 00531 3

We adapt the **shaft length** of our stirring tools to **your requirements** on request.
Please contact us for an individual consultation.

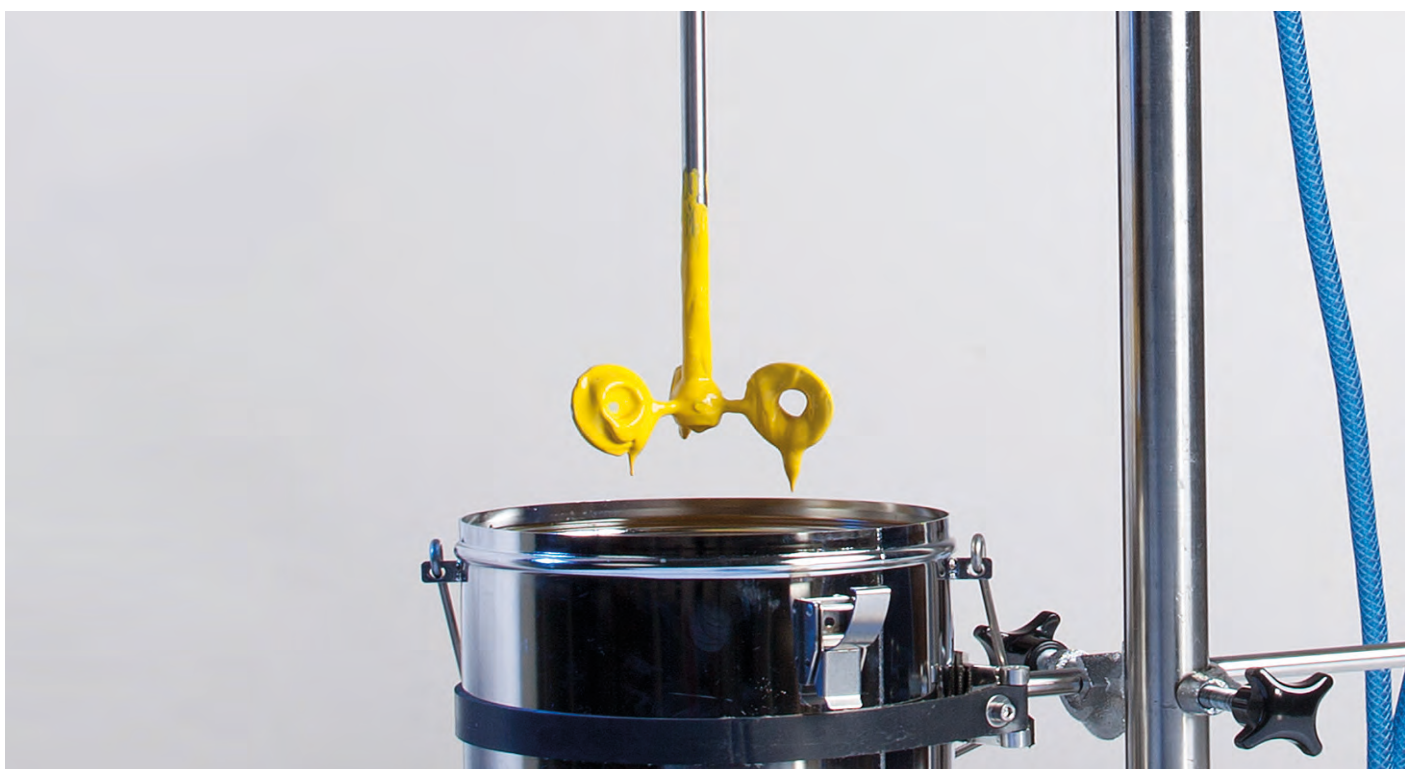

Propeller stirring rotor PR



Types of mixing

- Homogenising
- Suspending

Flow type

Axial

Characteristics

High energy input, medium to high shear forces

Speed range

Medium to high speed operations

Suitable stirrers

PM 64/30, PM 64/65 and PM 64/160 model series with connection coupling VK 14
PM 120/300, PM 120/600 and PM 120/1000 model series with connection coupling VK 19

Type	Material	Length	Stirrer Ø	Shaft Ø	Code-No.
PR 9	1.4404	850 mm	100 mm	14 mm	40 26446 00133 9
PR 10	1.4404	1000 mm	125 mm	14 mm	40 26446 00134 6
PR 11	1.4404	1000 mm	150 mm	14 mm	40 26446 00135 3
PR 13	1.4404	1000 mm	175 mm	14 mm	40 26446 00139 1
PR 15	1.4404	1000 mm	200 mm	20 mm	40 26446 00138 4
PR 17	1.4404	1000 mm	250 mm	20 mm	40 26446 00144 5

Dissolver stirring rotor DS



Types of mixing

- Dispersing

Flow type

Radial, turbulent

Characteristics

High speed rotor, high energy input, high shear forces

Speed range

High to very high speed operations

Viscosity range

Low to medium viscosity fluids

Suitable stirrers

PM 64/65 and PM 64/160 model series with connection coupling VK 14
PM 120/600 and PM 120/1000 model series with connection coupling VK 19

Type	Material	Length	Stirrer Ø	Shaft Ø	Code-No.
DS 7	1.4404	850 mm	100 mm	14 mm	40 26446 00149 0
DS 8	1.4404	850 mm	125 mm	14 mm	40 26446 00150 6
DS 9	1.4404	1000 mm	150 mm	14 mm	40 26446 00151 3
DS 10	1.4404	1000 mm	200 mm	20 mm	40 26446 00152 0
DS 11	1.4404	1000 mm	250 mm	20 mm	40 26446 00153 7

Swing-out stirring system BuddeMix SW

Types of mixing

- Homogenising
- Suspending
- Heat exchange

Flow type

Dynamic flow

Characteristics

No shear forces, little air inclusion.

For low to high viscosity fluids.

Foldable swing-out system to fit into small container openings (drums, IBC).

Speed range

Low to medium speed operations

Suitable stirrers

PM 64/30 and PM 64/65 model series with connection coupling VK 14

PM 120/300 and PM 120/600 model series with connection coupling VK 19

Type	Material	Length	Stirrer Ø	Ø folded	Shaft Ø	Code-No.
BuddeMix SW 4	1.4404	750 mm	300 mm	44 mm	14 mm	40 26446 00574 0
BuddeMix SW 2	1.4404	1000 mm	400 mm	78 mm	25 mm	40 26446 00539 9
BuddeMix SW 3	1.4404	1000 mm	500 mm	100 mm	25 mm	40 26446 00540 5
Residue paddle	1.4404	-	138 mm	-	-	40 26446 00513 9



BuddeMix SW



Residue paddle



BuddeMix SW with residue paddle



Bossheads



KR 260



KR 360



Assembly example

Clamping width max. 36 mm.

Type	Description	Code-No.
KR 260	Bosshead 10 - 36 mm	40 26446 00386 9
KR 360	Stainless steel bosshead 12 - 36 mm	40 26446 00815 4

Clamp holder SP



With bosshead KR 260, strap length 150 cm.

Type	Description	Code-No.
SP	Clamp holder with bosshead KR 260	40 26446 00792 8

Connection couplings VK

Fixed-diameter connection between motor and stirring shaft. Suitable for use in potentially explosive atmospheres (ATEX).

VK 14 suitable for PM 64 model series.
VK 19 suitable for PM 120 model series.



Type	Description	Receiver Ø	Material	To fit shaft Ø	Code-No.
VK 14 x 10	Connection coupling	14 x 10 mm	1.4404	10 mm	40 26446 00705 8
VK 14 x 12	Connection coupling	14 x 12 mm	1.4404	12 mm	40 26446 00647 1
VK 14 x 14	Connection coupling	14 x 14 mm	1.4404	14 mm	40 26446 00744 7
VK 14 x 20	Connection coupling	14 x 20 mm	1.4404	20 mm	40 26446 00079 0
VK 19 x 20	Connection coupling	19 x 20 mm	1.4404	20 mm	40 26446 00080 6
VK 19 x 25	Connection coupling	19 x 25 mm	1.4404	25 mm	40 26446 00550 1

VK 14 x 20 and VK 19 welded to the stirring rotor shaft.

Stands

Floor stand BS

With angled foot, powder-coated or stainless steel, see table, side length 500 mm, stainless steel rod Ø 34 mm.

Type	Description	Length	Code-No.
BS 1	Plastic coating / stainless steel	1000 mm	40 26446 00086 8
BS 2	Plastic coating / stainless steel	1500 mm	40 26446 00083 7
BS 3	All in stainless steel	1000 mm	40 26446 00826 0



BS1 and BS2



BS3

Service unit type WE



The service unit with filter, regulator and lubricator function provides both clean air with the recommended air purity class at the output and lubrication of motors.

2-piece combination consisting of filter pressure regulator and compressed air lubricator, pneumatic connection 1/4", filter porosity 40 µm, nominal flow rate 1600 l/min, with plastic bowls.

Type	Description	Code-No.
WE	Service unit	40 26446 00935 9

Motor oil

Motor oil for the food industry LT-Oil

Fully synthetic food grade oil according to NSF H1, FDA 21 CFR 178.3570.

Viscosity class 32.

Operating temperature -45°C to +135°C.

Cylinder oil

Resin-free and non-corrosive oil for lubrication of compressed air stirrers.

Viscosity class 32.



Type	Description	Code-No.
LT-Oil	Food grade oil 500 ml	40 26446 00955 7
Oil	Cylinder oil 500 ml	40 26446 00081 3

Desired model not included?

We will be pleased to provide you with customised solutions according to your specifications.

Please contact us for an individual consultation – we will find the best possible solution for your stirring process..



Your contact

Sabine Hohmann

+49 621 87690-40

hohmann@buddeberg.de



CONTAINER STIRRERS



The PMC series offers optimal stirrers for use with standard Intermediate Bulk Containers (IBC). Our PMC container stirrers are explosion-protected and certified for use in zone 0. Optimal mixing results are ensured by the special foldable swing-out stirring system including a residue level.

Our pneumatic IBC mixers can run dry without using any lubrication, on request equipped with an FDA-compliant shaft seal (back-to-back-seal).

All PMC series stirrers feature an exhaust air ducting. The light weight traverse support can be installed easily, quickly and safely without tools, no lifting devices are required.

All our compressed air stirrers are certified to ATEX regulation II 1/2G Ex h IIB T4 Ga/Gb.

Area of application: Paints and coatings industry, chemical industry, food industry.

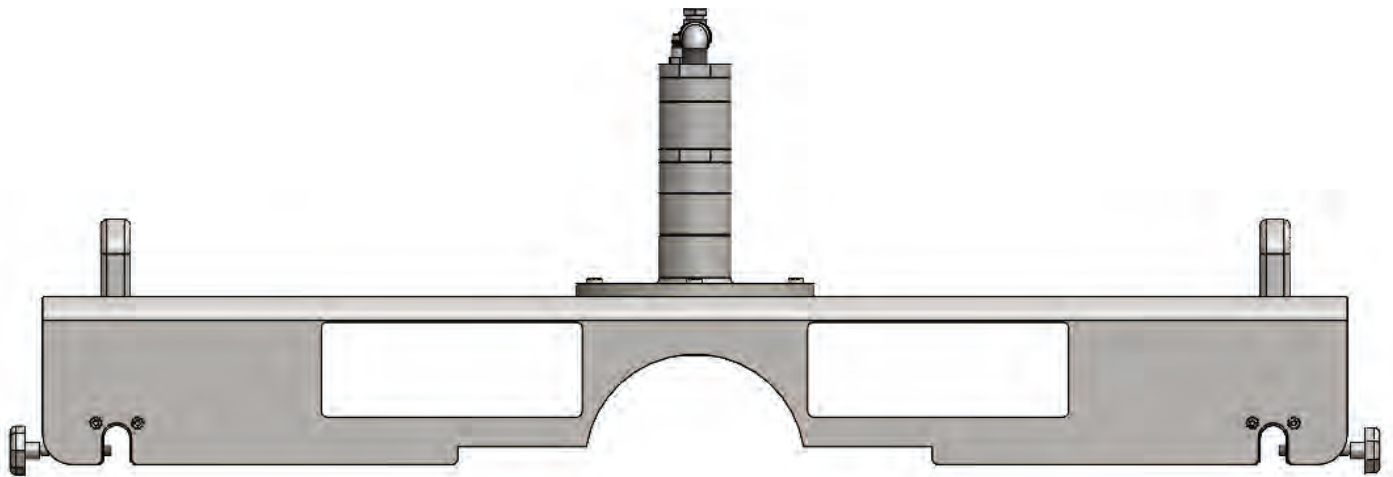

Volume



Volume up to 1500 litres

Custom made



We offer custom designs, tailored individually to your requirements

ATEX certification



Our container stirrers are explosion-protected according to the current ATEX regulation

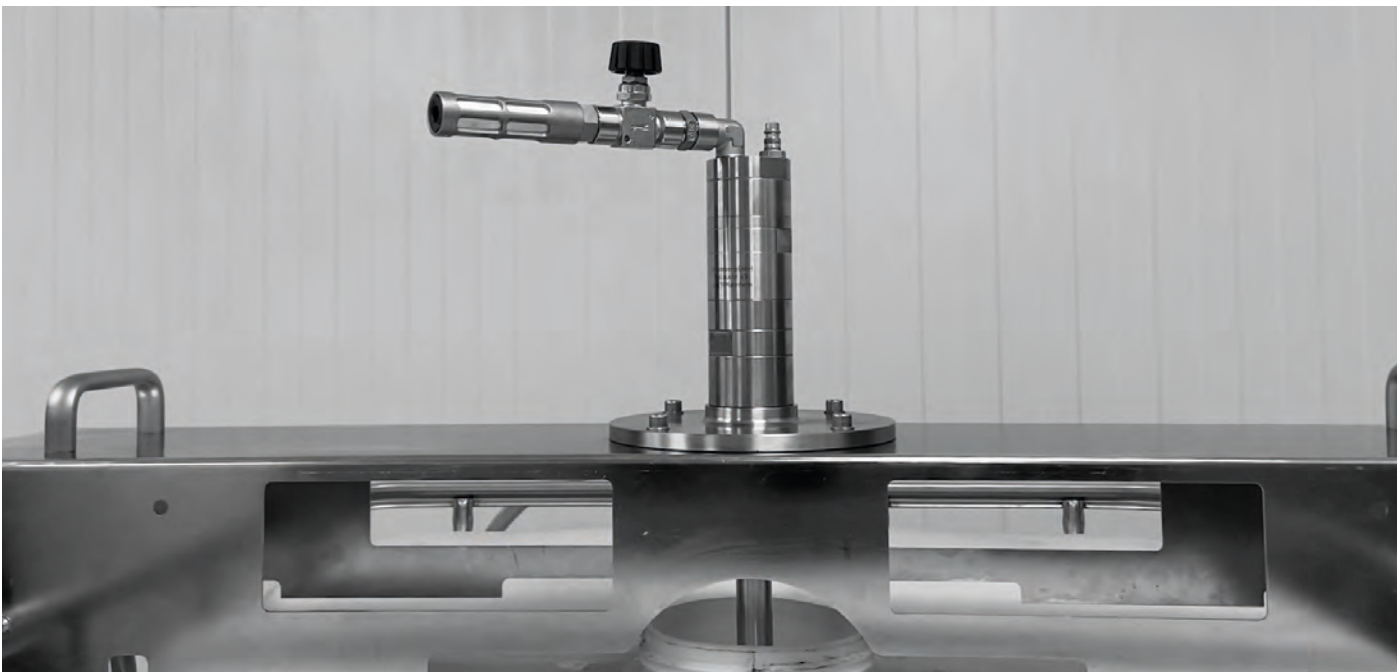

Compressed air container stirrers model series PMC 120/300

Suitable for stirring tasks in Intermediate Bulk Container IBC 600 L and 1000 L at low speed.

General specifications

- All-stainless steel housing
- Operating pressure 3-6 bar
- Air consumption 1380 L/min. at 6 bar
- Clockwise rotation
- ATEX certification



Basic models include

- Continuously adjustable speed control valve
- Plug-in connector for DN 7.8
- Silencer
- Traverse support to fit on standard IBC
- Foldable swing-out stirrer BuddeMix SW 2 Ø 400 mm
- Residue paddle Ø 138 mm

Types of mixing

- Homogenising
- Suspending
- Heat exchange

Speed range

- Low



Type	PMC 120/300
Viscosity	150000 mPas
Volume	1500 L
Power output	1.2 kW
No-load speed	300 rpm
Minimum operation speed	50 rpm
Torque	63 Nm
ATEX	II 1/2G Ex h IIB T4 Ga/Gb
Code-No.	40 26446 00810 0

All technical data pertaining to 6 bar. Viscosity data to be considered as guidelines.

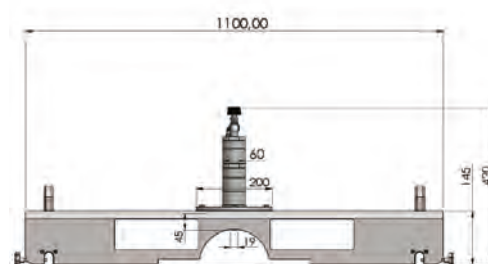

All dimensions in mm.

Compressed air container stirrers model series PMC 120/600

Suitable for stirring tasks in Intermediate Bulk Container IBC 600 L and 1000 L at medium speed.

General specifications

- All-stainless steel housing
- Operating pressure 3-6 bar
- Air consumption 1380 L/min. at 6 bar
- Clockwise rotation
- ATEX certification



Basic models include

- Continuously adjustable speed control valve
- Plug-in connector for DN 7.8
- Silencer
- Traverse support to fit on standard IBC
- Foldable swing-out stirrer BuddeMix SW 2 Ø 400 mm
- Residue paddle Ø 138 mm

Types of mixing

- Homogenising
- Suspending
- Heat exchange

Speed range

- Medium



Type	PMC 120/600
Viscosity	100000 mPas
Volume	1500 L
Power output	1.2 kW
No-load speed	600 rpm
Minimum operation speed	150 rpm
Torque	38 Nm
ATEX	II 1/2G Ex h IIB T4 Ga/Gb
Code-No.	40 26446 00811 6

All technical data pertaining to 6 bar. Viscosity data to be considered as guidelines.

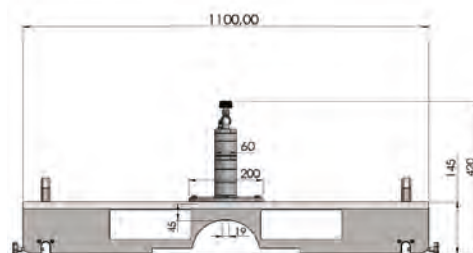

All dimensions in mm.



Swing-out stirring system BuddeMix SW

Types of mixing

- Homogenising
- Suspending
- Heat exchange

Flow type

Dynamic flow

Characteristics

No shear forces, little air inclusion.

For low to high viscosity fluids.

Foldable swing-out system to fit into small container openings (drums, IBC).

Speed range

Low to medium speed operations

Suitable stirrers

PMC 120/300 model series

PMC 120/600 model series



Type	Material	Length	Stirrer Ø	Ø folded	Shaft Ø	Code-No.
BuddeMix SW 2	1.4404	1000 mm	400 mm	78 mm	25 mm	40 26446 00539 9
BuddeMix SW 3	1.4404	1000 mm	500 mm	100 mm	25 mm	40 26446 00540 5
Residue paddle	1.4404	-	138 mm	-	-	40 26446 00513 9



MAGNETIC STIRRER COUPLINGS

MAGNETIC STIRRER DRIVES

Magnetic stirrer couplings are an ideal solution for stirring tasks under vacuum and high pressure. Stirring shaft rotation is achieved by magnetic coupling without any physical contact, so no moving parts require sealing. Operating pressures up to 700 bar and temperatures up to 550°C are possible.

We supply our magnetic stirrer couplings to users from research, industry, laboratory, colleges, universities, to apparatus engineers and constructors. The choice of various construction materials allows operation under aggressive chemical conditions. Different bearing options extend the field of applications even more.

Rare earth steel magnets are used, coated in the same material as the pressure-exposed section and welded tightly for operation under both low and high pressures.

Magnetic stirrer couplings require very little maintenance and their simple construction facilitates cleaning of the parts which come in contact with the stirred medium. Different bearings and/or construction materials are offered to accommodate almost any application requiring chemical resistance.

Additional connections, e.g. for gas purging or speed monitoring by means of a reed contact can be fitted.

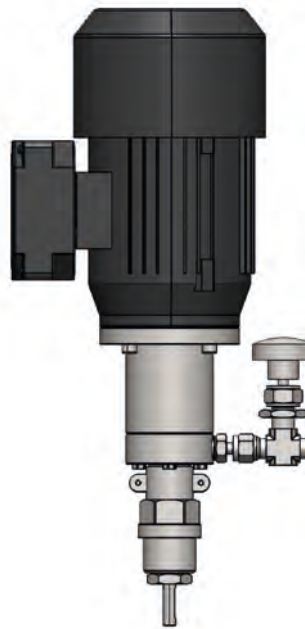

Volume



Volume up to 50 litres

Custom made



We offer custom designs, tailored individually to your requirements

ATEX certification on request



On request we can offer our magnetic stirrer couplings and drives explosion-protected



Magnetic stirrer couplings BUK S1 and S2 model series

Suitable for stirring tasks under vacuum.

The S1 and S2 design with standardised ground joint (vacuum-proof, unpressurised)

Magnetic stirrer couplings with NS 29/32 (S1) or NS 45/40 (S2) joint are specially designed for use in flasks and glass reactors with ground joint connections.

The encapsulated inner magnet couples to the external drive magnet bell and provides the drive force. This process involves absolutely gas-tight stirring.

The sealing takes place via O-rings on the conical part and is made of FKM as standard. Alternatively, these can also be equipped in FFKM of various qualities on request.

Types of mixing

-  Homogenising
-  Dispersing
-  Suspending
-  Gassing

Pressure

-  Vacuum, pressureless



Type	BUK K40 S1	BUK K90 S1	BUK K90 S2
Connection	NS 29/32	NS 29/32	NS 45/40
Temperature max.	240 °C	240 °C	240 °C
Pressure	Vacuum	Vacuum	Vacuum
Sealings	FKM O-rings	FKM O-rings	FKM O-rings
Material	1.4435 AISI 316L	1.4435 AISI 316L	1.4435 AISI 316L
Speed max.	2500 rpm	2500 rpm	2500 rpm
Torque	40 Ncm	90 Ncm	90 Ncm
Volume max.	5000 ml	10000 ml	10000 ml
Bearings	Ball bearings stainless steel	Ball bearings stainless steel	Ball bearings stainless steel
Reed contact and speed sensor	-	-	-
Gas flush connection	-	-	-
Drive motor	-	-	-
Code-No.	40 26446 00158 2	40 26446 00160 5	40 26446 00163 6

Drive shaft supplied with 6 mm external square stub.



All dimensions in mm.

Magnetic stirrer couplings BUK F model series

Suitable for stirring tasks under vacuum and pressure.

The F design with flanges DN15 and DN50 (vacuum-proof, pressure-resistant up to 10 bar)

Magnetic stirrer couplings with flanges DN 15 or DN 50 are intended in particular for use on glass reactors, thin film evaporators and extraction columns. This design is not only vacuum-proof but can also be used for applications with overpressure of up to 10 bar.

Standard flat gaskets, e.g. made of PTFE, can be selected as seals. Variants in special materials such as Hastelloy C22, C276, B3 are available on request. Other flange sizes and systems such as KF and TriClamp can also be realised.

Types of mixing

-  Homogenising
-  Dispersing
-  Suspending
-  Gassing

Pressure

-  Vacuum, 10 bar



Type	BUK K90 F15	BUK K90 F50
Connection	Flange DN15	Flange DN50
Temperature max.	240 °C	240 °C
Pressure	Vacuum / up to 10 bar	Vacuum / up to 10 bar
Sealings*	Flat gasket PTFE	Flat gasket PTFE
Material	1.4435 AISI 316L	1.4435 AISI 316L
Speed max.	2500 rpm	2500 rpm
Torque max.	90 Nm	90 Nm
Volume max.	10000 ml	10000 ml
Bearings	Ball bearings stainless steel	Ball bearings stainless steel
Reed contact and speed sensor	-	-
Gas flush connection	-	-
Drive motor	-	-
Code-No.	40 26446 00397 5	40 26446 00182 7

*Seal not included with delivery. Drive shaft supplied with 6 mm external square stub.

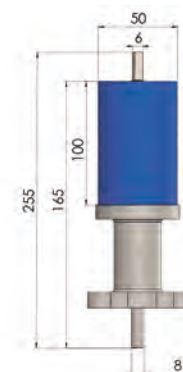
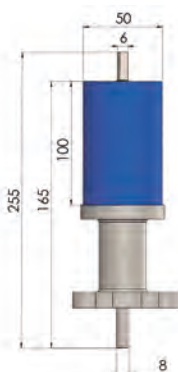

All dimensions in mm.

Magnetic stirrer couplings BUK G model series

The G design (vacuum-proof, pressure-resistant up to 700 bar)

Threaded magnetic stirrer couplings are the first choice for stirring processes under high to very high pressure. This design can be used for applications up to 200 bar (in the variant made of high-temperature-resistant alloy A-286, 1.4980 even up to 700 bar).

Variants in special materials such as Hastelloy C22, C276, B3 are available on request.

Types of mixing

-  Homogenising
-  Dispersing
-  Suspending
-  Gassing

Pressure

-  Vacuum / pressure up to 700 bar



Type	BUK K50G Mini	BUK K50G Mini HP	BUK K90G
Connection	Thread M18x1	Thread M18x1	Thread M30x2
Temperature max.	250 °C	250 °C	300 °C
Pressure max.	200 bar	700 bar	200 bar
Sealings*	O-ring FFKM or cutting ring HC22	O-ring FFKM or cutting ring HC22	O-ring FFKM or cutting ring HC22
Material	1.4435 AISI 316L	1.4980 Alloy A-286	1.4435 AISI 316L
Speed max.	2500 rpm	2500 rpm	2500 rpm
Torque	50 Ncm	50 Ncm	90 Ncm
Volume max.	1000 ml	1000 ml	10000 ml
Bearings	Ball bearings stainless steel	Ball bearings stainless steel	Ball bearings stainless steel
Reed contact and speed sensor	Yes	Yes	Yes
Gas flush connection	-	-	-
Drive motor	-	-	-
Code-No.	40 26446 00189 6	40 26446 00187 2	40 26446 00198 8

*Seal not included with delivery. Drive shaft supplied with 6 mm external square stub.

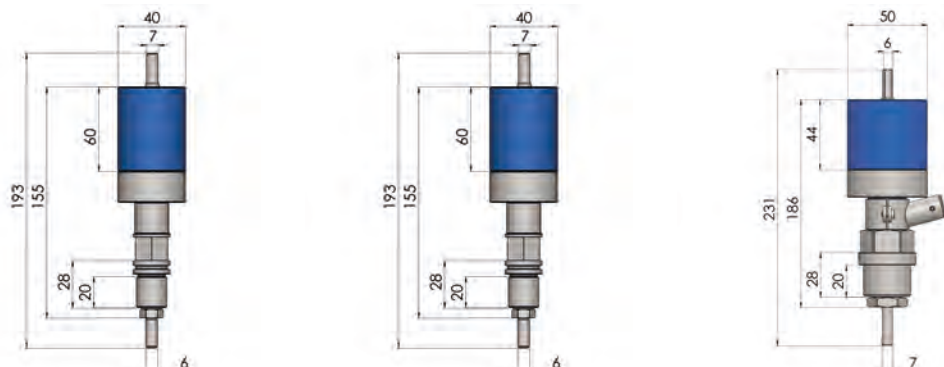

All dimensions in mm.

Magnetic stirrer couplings BUK G-V model series

The G-V design with M30 thread (vacuum-proof, pressure-resistant up to 200 bar)

The G-V design offers all the technical specifications of the G versions, but is additionally equipped with a side gas flush connection for gas flushing and inertisation.

A suitable gas flush valve is included in the scope of delivery and is already pre-assembled.

Types of mixing

-  Homogenising
-  Dispersing
-  Suspending
-  Gassing

Pressure

-  Vacuum / pressure up to 200 bar



Type	BUK K90G-V
Connection	Thread M30x2
Temperature max.	300 °C
Pressure max.	200 bar
Sealings*	O-ring FFKM or cutting ring HC22
Material	1.4435 AISI 316L
Speed max.	2500 rpm
Torque	90 Ncm
Volume max.	10000 ml
Bearings	Ball bearings stainless steel
Reed contact and speed sensor	Yes
Gas flush connection	Yes
Drive motor	-
Code-No.	40 26446 00209 1

*Seal not included with delivery. Drive shaft supplied with 6 mm external square stub.

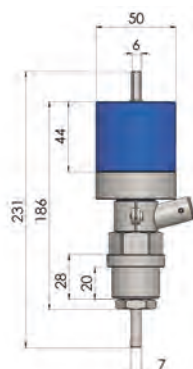

All dimensions in mm.

Diagonal blade stirring rotors PSR

Types of mixing

- Homogenising
- Suspending
- Dispersing

Flow type

Axial, turbulent

Characteristics

High energy input, high shear forces

Speed range

Medium to high speed operations

Suitable stirrers

Suitable for all BUK model series.

The shaft length is adapted to your container and must be specified when ordering.



Type	Material	Length	Stirrer Ø	Shaft Ø	Code-No.
PSR 1	1.4404	350 mm	50 mm	8 mm	40 26446 00115 5
PSR 1	1.4404	550 mm	50 mm	10 mm	40 26446 00740 9
PSR 3	1.4404	550 mm	100 mm	10 mm	40 26446 00796 6

Anchor stirring rotors AR

Types of mixing

- Homogenising
- Heat exchange

Flow type

Tangential, laminar

Characteristics

Operates at slow rotation speed, with low distance to the container wall

Speed range

Low to medium speed operations

Viscosity range

High to medium viscosity fluids

Suitable stirrers

Suitable for all BUK model series.

The shaft length is adapted to your container and must be specified when ordering.



Type	Material	Length	Stirrer Ø	Shaft Ø	Code-No.
AR 1	1.4404	500 mm	80 mm	10 mm	40 26446 00793 5
AR 2	1.4404	500 mm	100 mm	10 mm	40 26446 00794 2
AR 3	1.4404	500 mm	150 mm	10 mm	40 26446 00795 9

BuddeMix Stirring System

Types of mixing

- Homogenising
- Suspending
- Heat exchange

Flow type

Dynamic flow

Characteristics

No shear forces, little air inclusion

Speed range

Low to medium speed

Suitable stirrers

Suitable for all BUK model series.

The shaft length is adapted to your container and must be specified when ordering.



BuddeMix 1-4



BuddeMix Mini 30

Type	Material	Length	Stirrer Ø	Shaft Ø	Code-No.
BuddeMix Mini 30	1.4404	350 mm	35 mm	8 mm	40 26446 00806 2
BuddeMix 1	1.4404	350 mm	60 mm	10 mm	40 26446 00799 7
BuddeMix 2	1.4404	350 mm	80 mm	10 mm	40 26446 00535 1
BuddeMix 3	1.4404	550 mm	120 mm	10 mm	40 26446 00536 8
BuddeMix 4	1.4404	850 mm	150 mm	10 mm	40 26446 00537 5

Propeller stirring rotors, PTFE-coated

Types of mixing

- Homogenising
- Suspending

Flow type

Axial

Characteristics

High energy input, medium shear forces, superior chemical resistance

Speed range

Medium to high speed operations

Suitable stirrers

Suitable for all BUK model series.

The shaft length is adapted to your container and must be specified when ordering.



PRP1



PRP2

Type	Material	Length	Shaft Ø	to fit chuck	Paddle width	Paddle Ø	Code-No.
PRP 1	PTFE	600 mm	10 mm	8 mm	3 mm	75 mm	40 26446 00380 7
PRP 2	PTFE	800 mm	10 mm	8 mm	4 mm	140 mm	40 26446 00381 4

Propeller stirring rotors PR

Types of mixing

- Homogenising
- Suspending
- Dispersing

Flow type

Axial

Characteristics

High energy input, medium to high shear forces

Speed range

Medium to high speed operations

Suitable stirrers

Suitable for all BUK model series.

The shaft length is adapted to your container and must be specified when ordering.

Type	Material	Length	Stirrer Ø	Shaft Ø	Code-No.
PR 1	1.4404	350 mm	45 mm	8 mm	40 26446 00123 0
PR 3	1.4404	550 mm	140 mm	10 mm	40 26446 00125 4
PR 4	1.4404	850 mm	140 mm	10 mm	40 26446 00126 1
PR 5	1.4404	550 mm	75 mm	10 mm	40 26446 00766 9



PR 1,5



PR 3,4

Dissolver stirring rotors DS

Types of mixing

- Dispersing

Flow type

Radial, turbulent

Characteristics

High speed rotor, high energy input, high shear forces

Speed range

High to very high speed operations

Suitable stirrers

Suitable for all BUK model series.

The shaft length is adapted to your container and must be specified when ordering.



Type	Material	Length	Stirrer Ø	Shaft Ø	Code-No.
DS 1	1.4404	350 mm	30 mm	8 mm	40 26446 00109 4
DS 2	1.4404	350 mm	40 mm	10 mm	40 26446 00800 0
DS 3	1.4404	550 mm	50 mm	10 mm	40 26446 00677 8
DS 4	1.4404	550 mm	60 mm	10 mm	40 26446 00801 7
DS 5	1.4404	550 mm	70 mm	10 mm	40 26446 00802 4
DS 6	1.4404	550 mm	80 mm	10 mm	40 26446 00735 5



Connection couplings VKG for glass stirring shafts

For shaft diameter 8 and 10 mm.



Type	Suits	Material	Code-No.
VKG 7	Joint BUK	1.4435 (AISI 316L)	40 26446 00472 9
VKG 8	Flange BUK	1.4435 (AISI 316L)	40 26446 00473 6

Connection couplings between stirring motor and magnetic stirrer coupling

Double-cardan-coupling DCK made of stainless steel.

DCK I with stud to be used with a chuck. DCK II suits PLR stirrers.



Type	Receiver drive side	Clamp width, output side	Length	Code-No.
DCK I	external hex 8 mm	square socket 6 mm	110 mm	40 26446 00141 4
DCK II	i.d. 10 mm	square socket 6 mm	110 mm	40 26446 00368 5

Cardan coupling PK made of plastic



Colour may vary

Type	Receiver drive side	Clamp width, output side	Length	Code-No.
PK 10	i.d. 10 mm	6-10 mm	80 mm	40 26446 00058 5
PK 10/13	i.d. 10/13 mm	6-10 mm	80 mm	40 26446 00059 2

Connection couplings between stirring motor and magnetic stirrer coupling



Type	Receiver drive side	Clamp width, output side	Length	Code-No.
K 10	i.d. 10 mm	6-10 mm	105 mm	40 26446 00054 7
K 10/13	i.d. 10/13 mm	6-10 mm	105 mm	40 26446 00055 4
FK 1	with stud Ø 8 mm	6-10 mm	108 mm	40 26446 00595 5

Connection couplings VK

Fixed-diameter connection between drive/magnetic coupling and stirring shafts.
Suitable for use in potentially explosive atmospheres (ATEX).
Suitable for all BUK models.



Type	Description	Receiver Ø	Material	To fit shaft Ø	Code-No.
VK 7 x 6	Connection coupling	7 x 6 mm	1.4404	6 mm	40 26446 00803 1
VK 7 x 8	Connection coupling	7 x 8 mm	1.4404	8 mm	40 26446 00746 1
VK 7 x 10	Connection coupling	7 x 10 mm	1.4404	10 mm	40 26446 00036 3

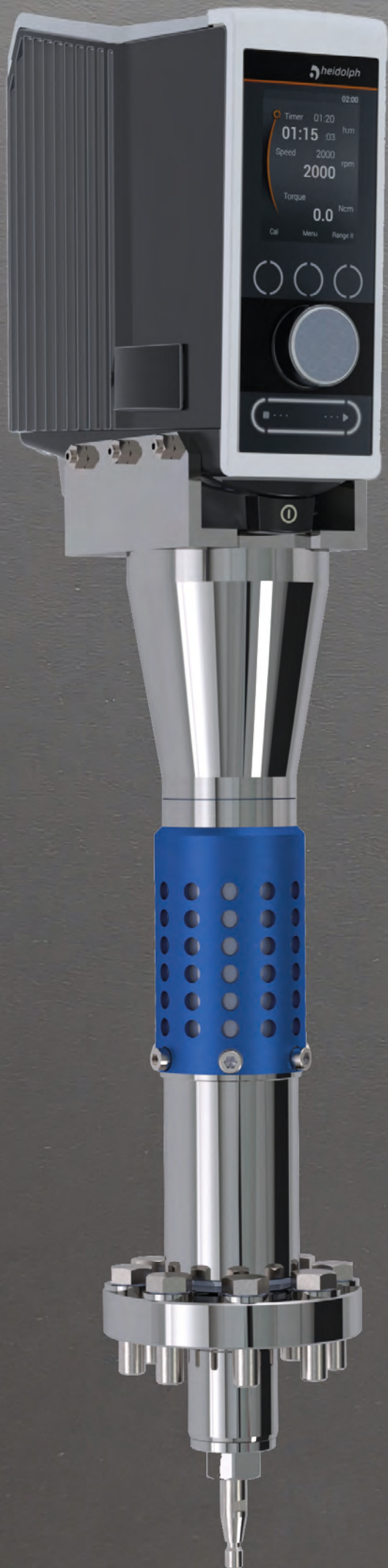

MAGNETIC STIRRER COUPLINGS AND MAGNETIC STIRRER DRIVES TAILORED TO YOUR WISHES

We provide you with individual consultations during the planning phase and offer custom designed magnetic stirrer couplings and magnetic stirrer drives that meet your special requirements.

Magnetic stirrer drives BUK M model series with motor

The M design with drive motor (vacuum-proof, pressure-resistant up to 200 bar)

Magnetic stirrer drives offer all the advantages of the G design couplings and are additionally equipped with a three-phase motor. This combination can be used for applications up to 200 bar (in the variant made of high-temperature-resistant alloy A-286, 1.4980 even up to 700 bar). It can be controlled either by means of a frequency inverter or via a hand wheel on the ball roller gearbox.

Variants in special materials such as Hastelloy C22, C276, B3 are available on request.

Types of mixing

-  Homogenising
-  Dispersing
-  Suspending
-  Gassing

Pressure

-  Vacuum / pressure up to 200 bar



Type	BUK M90G	BUK M500G	BUK M800G
Connection	Thread M30x2	Thread M45x1,5	Thread M60x1,5
Temperature	300 °C	300 °C	300 °C
Pressure max.	200 bar	200 bar	200 bar
Sealings*	O-ring FFKM or cutting ring HC22	O-ring FFKM or cutting ring HC22	O-ring FFKM or cutting ring HC22
Material	1.4435 AISI 316L	1.4435 AISI 316L	1.4435 AISI 316L
Speed max.	1000 rpm	1000 rpm	1000 rpm
Torque	90 Ncm	500 Ncm	800 Ncm
Volume max.	10000 ml	30000 ml	50000 ml
Bearings	Ball bearings stainless steel	Ball bearings stainless steel	Ball bearings stainless steel
Reed contact and speed sensor	Yes	Yes	Yes
Gas flush connection	Yes	Yes	Yes
Drive motor	Yes	Yes	Yes
Code-No.	40 26446 00227 5	40 26446 00234 3	40 26446 00238 1

*Seal not included with delivery.

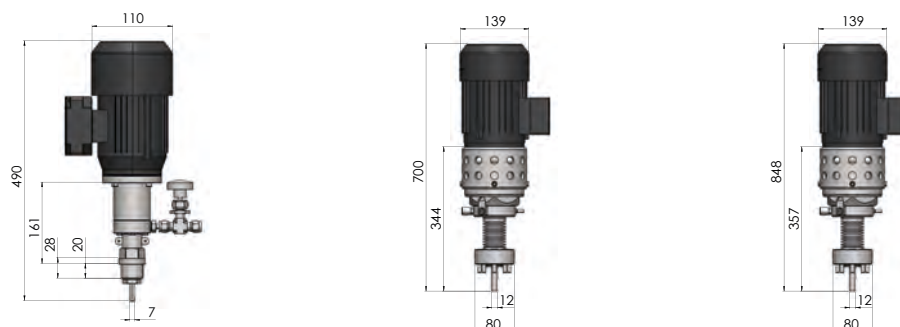

All dimensions in mm.

IMPRINT

Produced by

Buddeberg GmbH

Mallaustr. 49

68219 Mannheim

Phone: +49 621 87690-0

Mail: info@buddeberg.de

Web: www.buddeberg.de • www.buddeberg-ruehrtechnik.de

Managing Directors:

Myriam Bohlender, Hubert Bohlender

Typography

Sabine Hohmann

Marcel Schreiber

Marcel Bahrtdt

Buddeberg GmbH

Design

Julia Proegler

Buddeberg GmbH

Copyright 2024 by Buddeberg GmbH

No part of this catalogue may be re-produced without written consent. Every effort has been made to ensure that the descriptions given in this catalogue were correct at the time of going to press, but we accept no liability for any error. Our General Terms and Conditions apply.
Errors and omissions excepted.

A	
Anchor stirring rotors AR	21, 68
B	
Bossheads	37, 52
Bossheads for laboratory stirrers	28
BuddeMix Stirring System for laboratory stirrers / BUK	20, 69
BuddeMix Stirring System 5-7 for pharma/food grade stirrers	35
BuddeMix stirring system for industrial stirrers	49
C	
Clamp holder SP	28, 36, 52
Connection couplings for BUK	72, 73
Connection couplings VK	25, 73
Connection couplings VK for industrial stirrers	53
Connection couplings VK for pharma/food stirrers	36
Connection couplings VKG for glass stirring shafts	72
Container stirrers model series PMC 120/300	58
Container stirrers model series PMC 120/600	59
D	
Diagonal blade stirring rotors PSR	21, 68
Dissolver stirring rotor DS 7 - 11	50
Dissolver stirring rotors DS 1 - 6	23, 71
F	
Finger-operated oiler OT	29
Flexible glass stirring shaft couplings K	25
Flexible glass stirring shaft couplings PK	25
H	
Heating bath liquid BUDDE	27
I	
Industrial stirrers model series PM 64/30	44-45
Industrial stirrers model series PM 64/65	42-43
Industrial stirrers model series PM 64/160	40-41
Industrial stirrers model series PM 120/300	46
Industrial stirrers model series PM 120/600	47
Industrial stirrers model series PM 120/1000	48
L	
Laboratory stirrers PLR 10 model series	12-13
Laboratory stirrers PLR 11 model series	14-15
Laboratory stirrers PLR 12 model series	16-17
Laboratory stirrers PLR 28 model series	18-19
M	
Magnetic stirrer couplings BUK F model series	65
Magnetic stirrer couplings BUK G-V model series	67
Magnetic stirrer couplings BUK G model series	66
Magnetic stirrer couplings BUK S1 and S2 model series	64
Magnetic stirrer drives BUK M model series with motor	75
Motor oil	26, 37, 54
P	
Pharma/food grade stirrers model series PLM 38/260	34
Pharma/food grade stirrers model series PLM 38/580	33
Pharma/food grade stirrers model series PLM 38/1180	32
Propeller stirring rotor PR for industrial stirrers	50
Propeller stirring rotors PR for laboratory stirrers / BUK	22, 70
Propeller stirring rotors, PTFE-coated	24, 69
S	
Service unit type WE	29, 37, 54
Stands	26, 36, 53
Stirring shaft protection RWS	29
Swing-out stirring system BuddeMix SW for container stirrers	61
Swing-out stirring system BuddeMix SW for industrial stirrers	51



Buddeberg GmbH • Mallastr. 49 • 68219 Mannheim, Germany

Phone: +49 621 87690-0 Mail: info@buddeberg.de
Fax: +49 621 87690-95 Web: www.buddeberg-ruehrtechnik.de • www.buddeberg.de